

AXOR®

hansgrohe

DE	Gebrauchsanleitung / Montageanleitung	2
FR	Mode d'emploi / Instructions de montage	3
EN	Instructions for use / assembly instructions	4
IT	Istruzioni per l'uso / Istruzioni per Installazione	5
ES	Modo de empleo / Instrucciones de montaje	6
NL	Gebruiksaanwijzing / Handleiding	7
DK	Brugsanvisning / Monteringsvejledning	8
PT	Instruções para uso / Manual de Instalação	9
PL	Instrukcja obsługi / Instrukcja montażu	10
CS	Návod k použití / Montážní návod	11
SK	Návod na použitie / Montážny návod	12
ZH	用户手册 / 组装说明	13
RU	Руководство пользователя / Инструкция по монтажу	14
HU	Használati útmutató / Szerelési útmutató	16
FI	Käyttöohje / Asennusohje	17
SV	Brugsanvisning / Monteringsanvisning	18
LT	Vartotojo instrukcija / Montavimo instrukcijos	19
HR	Upute za uporabu / Uputstva za instalaciju	20
TR	Kullanım kılavuzu / Montaj kılavuzu	21
RO	Manual de utilizare / Instrucțiuni de montare	22
EL	Οδηγίες χρήσης / Οδηγία συναρμολόγησης	23
SL	Navodilo za uporabo / Navodila za montažo	24
ET	Kasutusjuhend / Paigaldusjuhend	25
LV	Lietošanas pamācība / Montāžas instrukcija	26
SR	Uputstvo za upotrebu / Uputstvo za montažu	27
NO	Brugsanvisning / Montasjeveiledning	28
BG	Инструкция за употреба / Ръководство за монтаж	29
SQ	Udhëzuesi i përdorimit / Udhëzime rreth montimit	30
AR	دليل الاستخدام / تعليمات التجميع	31

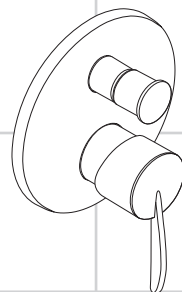

Starck

10415000 / 10415003 /
10417000

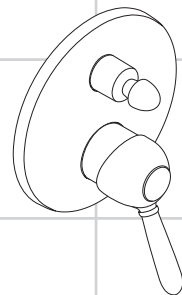

Carlton

17415XXX / 17417XXX



Sicherheitshinweise

- ⚠ Bei der Montage müssen zur Vermeidung von Quetsch- und Schnittverletzungen Handschuhe getragen werden.
- ⚠ Das Produkt darf nur zu Bade-, Hygiene- und Körperreinigungszwecken eingesetzt werden.
- ⚠ Große Druckunterschiede zwischen den Kalt- und Warmwasseranschlüssen müssen ausgeglichen werden.

Montagehinweise

- Vor der Montage muss das Produkt auf Transportschäden untersucht werden. Nach dem Einbau werden keine Transport- oder Oberflächenschäden anerkannt.
- Die Armatur muss nach den gültigen Normen montiert, gespült und geprüft werden.

Technische Daten

Betriebsdruck:	max. 1 MPa
Empfohlener Betriebsdruck:	0,1 - 0,5 MPa
Prüfdruck:	1,6 MPa
(1 MPa = 10 bar = 147 PSI)	
Heißwassertemperatur:	max. 80 °C
Empfohlene Heißwassertemperatur:	65 °C
Thermische Desinfektion:	max. 70 °C / 4 min

10417000 / 17417XXX . Eigensicher gegen Rückfließen

Das Produkt ist ausschließlich für Trinkwasser konzipiert!

Hansgrohe Armaturen können in Verbindung mit hydraulisch und thermisch gesteuerten Durchlauferhitzern eingesetzt werden, wenn der Fließdruck mindestens 0,15 MPa beträgt.

Störung	Ursache	Abhilfe
Armatur schwergängig	- Kartusche defekt, verkalkt	- Kartusche austauschen
Armatur tropft	- Kartusche defekt, Ablagerungen	- Kartusche austauschen
Umsteller funktioniert nicht	- Ablagerungen	- Umsteller reinigen / O-Ringe fetten
	- Zu geringer Wasserdruck	- Wasserdruck erhöhen
	- Umsteller defekt	- Umsteller austauschen
Zu niedrige Warmwassertemperatur, kein Kaltwasser. Durchlauferhitzer springt an, wenn Kaltwasser angewählt wird.	- Warmwasserbegrenzung falsch eingestellt	- Warmwasserbegrenzung einstellen
	- Kreuzfluss	- Kartusche austauschen

Symbolerklärung



Kein essigsäurehaltiges Silikon verwenden!



Justierung (siehe Seite 33)

Einhandmischer mit Warmwasserbegrenzung, Justierung siehe Seite 33. In Verbindung mit Durchlauferhitzern ist eine Warmwassersperre nicht zu empfehlen.



Maße (siehe Seite 34)



Durchflussdiagramm (siehe Seite 34)

- ① Abgang Brause
- ② Abgang Wanne



Bedienung (siehe Seite 35)



Wartung (siehe Seite 36)

10417000 / 17417XXX : Die Sicherheitseinrichtungen müssen gemäß DIN EN 1717 regelmäßig in Übereinstimmung mit nationalen oder regionalen Bestimmungen (DIN 1988 einmal jährlich) auf ihre Funktion geprüft werden.



Reinigung

Reinigung siehe beiliegende Broschüre.



Serviceteile (siehe Seite 38)





Prüfzeichen (siehe Seite 40)





Consignes de sécurité

-  Lors du montage, porter des gants de protection pour éviter toute blessure par écrasement ou coupure.
-  Le système de douche ne doit servir qu'à se laver et à assurer l'hygiène corporelle.
-  Il est conseillé d'équilibrer les pressions de l'eau chaude et froide.

Instructions pour le montage

- Avant son montage, s'assurer que le produit n'a subi aucun dommage pendant le transport. Après le montage, tout dommage de transport ou de surface ne pourra pas être reconnu.
- La robinetterie doit être installée, rincée et contrôlée conformément aux normes valables.

Informations techniques

Pression de service autorisée:	max. 1 MPa
Pression de service conseillée:	0,1 - 0,5 MPa
Pression maximum de contrôle:	1,6 MPa
(1 MPa = 10 bar = 147 PSI)	
Température d'eau chaude:	max. 80 °C
Température recommandée:	65 °C
Désinfection thermique:	max. 70 °C / 4 min

10417000 / 17417XXX. Avec dispositif anti-retour

Le produit est exclusivement conçu pour de l'eau potable!

Les mitigeurs Hansgrohe fonctionnent également en association à des chauffe-eau à commande hydraulique ou thermique à condition que la pression soit au minimum de 0,15 MPa.

Description du symbole



Ne pas utiliser de silicone contenant de l'acide acétique!



Étalonnage (voir page 33)

Mitigeur avec limitation de la température: voir la page 33 pour le réglage. Une limitation de la température n'est pas recommandée quand le mitigeur est alimenté par un chauffe-eau instantané.



Dimensions (voir page 34)

Diagramme du débit (voir page 34)

- ① Sortie douche
- ② Sortie baignoire



Instructions de service (voir page 35)

Entretien (voir page 36)

10417000 / 17417XXX: Les clapets anti-retour doivent être examinés régulièrement conformément à la norme EN 1717 ou conformément aux dispositions nationales ou régionales quant à leur fonction (au moins une fois par an).



Nettoyage

Pour les conseils d'entretien, voir la brochure ci-jointe.



Pièces détachées (voir pages 38)



Classification acoustique et débit (voir page 40)



Dysfonctionnement	Origine	Solution
Dureté de fonctionnement	- Cartouche défectueuse, entartrée	- Changer la cartouche
Le mitigeur goutte	- Cartouche défectueuse, entartrée	- Changer la cartouche
L'inverseur ne fonctionne pas	- Dépôts	- Nettoyer l'inverseur / graisser les joints toriques
	- Pression d'alimentation insuffisante	- Augmenter la pression d'alimentation
	- Inverseur défectueux	- Changez l'inverseur
Température d'eau chaude trop basse, pas d'eau froide. Le chauffe-eau instantané met en route quand on puise de l'eau froide.	- Limiteur de température mal positionné	- Positionner le limiteur de température
	- Flux inversé	- Changer la cartouche



Montage voir page 31



Safety Notes

-  Gloves should be worn during installation to prevent crushing and cutting injuries.
-  The shower system may only be used for bathing, hygienic and body cleansing purposes.
-  The hot and cold supplies must be of equal pressures.

Installation Instructions

- Prior to installation, inspect the product for transport damages. After it has been installed, no transport or surface damage will be honoured.
- The fitting must be installed, flushed and tested after the valid norms.

Technical Data

Operating pressure:	max. 1 MPa
Recommended operating pressure:	0,1 - 0,5 MPa
Test pressure:	1,6 MPa
(1 MPa = 10 bar = 147 PSI)	
Hot water temperature:	max. 80 °C
Recommended hot water temp.:	65 °C
Thermal disinfection:	max. 70 °C / 4 min

10417000 / 17417XXX. Safety against backflow

The product is exclusively designed for drinking water!

Hansgrohe mixers can be used together with hydraulically and thermally controlled continuous flow heaters if the flow pressure is at least 0,15 MPa.

Symbol description



Do not use silicone containing acetic acid!



Adjustment (see page 33)

To adjust the hot water limiter on single lever mixers, please see page 33. Using a hot water limiter in connection with a continuous flow water heater is not recommended.



Dimensions (see page 34)



Flow diagram (see page 34)

- ① Shower outlet
- ② Tub outlet



Operation (see page 35)



Maintenance (see page 36)

10417000 / 17417XXX: The safety device must be checked regularly according to DIN EN 1717 in accordance with national or regional regulations (at least once a year).



Cleaning

Cleaning recommendations, see enclosed brochure.



Spare parts (see page 38)





Test certificate (see page 40)

Fault	Cause	Remedy
Mixer stiff	- Cartridge defective, calcified	- Exchange cartridge
Mixer dripping	- Cartridge defective, sedimentation	- Exchange cartridge
Diverter not operating	- Residue	- Clean converter / grease O-rings
	- Water pressure too low	- Increase water pressure
	- Diverter defective	- Exchange diverter
Hot water temperature too low, no cold water. Instantaneous water heater starts up when cold water is selected.	- Hot water limiter incorrectly set	- Set hot water limiter
	- Crossflow	- Exchange cartridge





Indicazioni sulla sicurezza

-  Durante il montaggio, per evitare ferite da schiacciamento e da taglio bisogna indossare guanti protettivi.
-  Il sistema doccia deve essere utilizzato esclusivamente per l'igiene del corpo.
-  **Attenzione!** Compensare le differenze di pressione tra i collegamenti dell'acqua fredda e dell'acqua calda.

Istruzioni per il montaggio

- Prima del montaggio è necessario controllare che non ci siano stati danni durante il trasporto. Una volta eseguito il montaggio, non verranno riconosciuti eventuali danni di trasporto o delle superfici.
- La rubinetteria deve essere installata, pulita e testata secondo le istruzioni riportate!

Dati tecnici

Pressione d'uso:	max. 1 MPa
Pressione d'uso consigliata:	0,1 - 0,5 MPa
Pressione di prova:	1,6 MPa
(1 MPa = 10 bar = 147 PSI)	
Temperatura dell'acqua calda:	max. 80°C
Temp. dell'acqua calda consigliata:	65°C
Disinfezione termica:	max. 70°C / 4 min

10417000 / 17417XXX. Sicurezza antiriflusso

Il prodotto è concepito esclusivamente per acqua potabile!

I miscelatori Hansgrohe possono venire usati con caldaie a "bassa pressione" se la pressione di flusso è almeno di 0,15 MPa.

Descrizione simbolo



Non utilizzare silicone contenente acido acetico!



Taratura (vedi pagg. 33)

Per la regolazione del limitatore di erogazione di acqua calda dei miscelatori monocomando, vedi Pagina 33. Un limitatore di erogazione di acqua calda in combinazione con le caldaie istantanee non è consigliabile.



Ingombri (vedi pagg. 34)



Diagramma flusso
(vedi pagg. 34)

- ① uscita doccia
- ② uscita vasca



Procedura (vedi pagg. 35)



Manutenzione (vedi pagg. 36)

10417000 / 17417XXX: La valvola di non ritorno deve essere controllata regolarmente come da DIN EN 1717, secondo le normative nazionali e regionali (almeno una volta all'anno).



Pulitura

Suggerimenti per la pulizia: vedi il prospetto accluso.



Parti di ricambio (vedi pagg. 38)



Segno di verifica (vedi pagg. 40)

Problema	Possibile causa	Rimedio
Miscelatore duro	- Cartuccia difettosa	- Sostituire la cartuccia
Miscelatore gocciola	- cartuccia difettosa	- Sostituire la cartuccia
Deviatore non funziona	- depositi calcarei	- pulire il regolatore / ingrassare le guarnizioni O-ring
	- pressione d'acqua troppo bassa	- alzare la pressione d'acqua
	- deviatore difettoso	- sostituire deviatore
Temperatura dell'acqua calda troppo bassa, niente acqua fredda, caldaia istantanea si accende quando si seleziona acqua fredda	- Limitazione dell'acqua calda regolata male	- Regolare la limitazione dell'acqua calda
	- Flusso incrociato	- Sostituire la cartuccia



Montaggio vedi pagg. 31



Indicaciones de seguridad

- ⚠ Durante el montaje deben utilizarse guantes para evitar heridas por aplastamiento o corte.
- ⚠ La grifería solo debe ser utilizada para fines de baño, higiene y limpieza corporal.
- ⚠ Grandes diferencias de presión en servicio entre agua fría y agua caliente deben equilibrarse.

Indicaciones para el montaje

- Antes del montaje se debe examinarse el producto contra daños de transporte. Después de la instalación se se reconoce ningún daño de transporte o de superficie.
- El grifo tiene que ser instalado, probado y testado, según las normas en vigor.

Datos técnicos

Presión en servicio:	max. 1 MPa
Presión recomendada en servicio:	0,1 - 0,5 MPa
Presión de prueba:	1,6 MPa
(1 MPa = 10 bar = 147 PSI)	
Temperatura del agua caliente:	max. 80 °C
Temp. recomendada del agua caliente:	65 °C
Desinfección térmica:	max. 70 °C / 4 min

10417000 / 17417XXX . Seguro contra el retorno

El producto ha sido concebido exclusivamente para agua potable.

Los mezcladores Hansgrohe pueden ser utilizados junto con calentadores continuos de agua que sean manejados de manera hidráulica o térmica, siempre que la presión en servicio ascienda a un mínimo de 0,15 MPa.

Descripción de símbolos



No utilizar silicona que contiene ácido acético!



Ajuste (ver página 33)

Uso como mezclador monomando con limitación del caudal de agua caliente: ver ajuste en pagina 33. En combinación con calentadores instantáneos no es recomendable limitar el caudal de agua caliente.



Dimensiones (ver página 34)



Diagrama de circulación (ver página 34)

- ① Salida surtidor de ducha
- ② Salida bañera



Manejo (ver página 35)



Mantenimiento (ver página 36)

10417000 / 17417XXX: Las válvulas anti-retorno tienen que ser controladas regularmente según la norma DIN EN 1717, en acuerdo con las regulaciones nacionales o regionales (una vez al año, por lo menos).



Limpiar

Para las instrucciones de limpieza, ver el folleto adjunto.



Repuestos (ver página 38)





Marca de verificación (ver página 40)

Problema	Causa	Solución
Manecilla va dura	- cartucho dañado	- cambiar el cartucho
Grifo pierde agua	- cartucho calcificado / dañado	- cambiar el cartucho
Inversor no funciona	- Depósitos	- Limpiar conmutador de tomas / engrasar anillos tóricos
	- falta presión	- aumentar presión
	- inversor defecto	- cambiar inversor
Temperatura del agua caliente demasiado baja, agua fría	- tope de agua caliente mal	- ajustar tope
calentador se dispara al abrir agua fría	- Flujo cruzado	- cambiar el cartucho





Veiligheidsinstructies

-  Bij de montage moeten ter voorkoming van knel- en snijwonden handschoenen worden gedragen.
-  Het douchesysteem mag alleen voor het wassen, hygiënische doeleinden en voor de lichaamreiniging worden gebruikt.
-  Grote drukverschillen tussen de koud- en warmwatertoevoer dienen vermeden te worden.

Montage-instructies

- Vóór de montage moet het product gecontroleerd worden op transportschade. Na de inbouw wordt geen transport- of oppervlakteschade meer aanvaard.
- Leidingen doorspoelen volgens Norm. De mengkraan vervolgens monteren en controleren.

Technische gegevens

Werkdruk: max.	max. 1 MPa
Aanbevolen werkdruk:	0,1 - 0,5 MPa
Getest bij:	1,6 MPa
(1 MPa = 10 bar = 147 PSI)	
Temperatuur warm water:	max. 80 °C
Aanbevolen warm water temp.:	65 °C
Thermische desinfectie:	max. 70 °C / 4 min

10417000 / 17417XXX. Beveiligd tegen terugstromen

Het product is uitsluitend ontworpen voor drinkwater!

Hansgrohe kranen kunnen samen met hydraulisch en thermisch gestuurde geisers gebruikt worden indien de uitstroomdruk min. 0,15 MPa bedraagt.

Symboolbeschrijving



Gebruik geen zuurhoudende silicone!



Instellen (zie blz. 33)

Eéngreepsmengkranen met warmwaterbegrenzing, instelling zie blz. 33. In combinatie met geisers wordt een warmwaterbegrenzing niet aanbevolen.



Maten (zie blz. 34)



Doorstroombiagram
(zie blz. 34)

- ① Uitlaat douche
- ② Uitlaat bad



Bediening (zie blz. 35)



Onderhoud (zie blz. 36)

10417000 / 17417XXX: Keerkleppen moeten volgens DIN EN 1717 regelmatig en volgens plaatselijk geldende eisen op het functioneren gecontroleerd worden. (Tenminste een keer per jaar)



Reinigen

Reinigingsadvies zie bijgevoegde brochure.



Service onderdelen (zie blz. 38)



Keurmerk (zie blz. 40)

Storing	Oorzaak	Oplossing
Bediening zwaar	- Kardoes defect of verkalkt	- Kardoes uitwisselen
Mengkraan lekt	- Kardoes defect of vervuild	- Kardoes uitwisselen
Omstelling functioneert niet	- Afzettingen	- Omsteller reinigen / O-ringen invetten
	- Waterdruk te laag	- Waterdruk verhogen
	- Omstelling defect	- Omstelling uitwiss
Warmwater temperatuur te laag, geen koud water. Doorstroombiagram springt aan wanneer koud water gekozen is.	- Heetwaterbegrenzer verkeerd ingesteld	- Heetwaterbegrenzer instellen
	- Kruisstroomb	- Kardoes uitwisselen



Montage zie blz. 31



Sikkerhedsanvisninger

- △ Ved monteringen skal der bruges handsker for at undgå kvæstelser og snitsår.
- △ Brusersystemet må kun bruges til bade-, hygiejne og rengøringsformål.
- △ Større trykforskel mellem koldt og varmt vand bør udjævnes.

Monteringsanvisninger

- Før monteringen skal produktet kontrolleres for transportskader. Efter monteringen godkendes transportskader eller skader på overfladen ikke længere.
- Ifølge gældende regler, skal armaturet monteres, skylles igennem og afprøves.

Tekniske data

Driftstryk:	max. 1 MPa
Anbefalet driftstryk:	0,1 - 0,5 MPa
Prøvetryk:	1,6 MPa
(1 MPa = 10 bar = 147 PSI)	
Varmtvandstemperatur:	max. 80 °C
Anbefalet varmtvandstemperatur:	65 °C
Termisk desinfektion:	max. 70 °C / 4 min

10417000 / 17417XXX. Med indbygget kontraventil

Produktet er udelukkende beregnet til drikkevand!

Hansgrohe armaturer kan anvendes i forbindelse med hydraulisk- og termiskstyrede gennemstrømningsvandvarmere ved et vandtryk på 0,15 MPa.

Symbolbeskrivelse



Der må ikke benyttes eddikesyreholdig silikone!



Forindstilling (se s. 33)

Etgrebsarmaturer med varmtvandsbegrænsning, justering se side 33. I forbindelse med gennemstrømningsvandvarmer anbefales en varmtvandsbegrænsning ikke.

Målene (se s. 34)



Gennemstrømningsdiagram (se s. 34)

- ① Afløb bruser
- ② Afløb kar



Brugsanvisning (se s. 35)



Service (se s. 36)

10417000 / 17417XXX: Ifølge DIN EN 1717 skal gennemstrømningsbegrænsere i overensstemmelse med nationale regler afprøves regelmæssigt (mindst en gang om året).



Rengøring

For anbefalinger til rengøringen, se venligst den vedlagte brochure.



Reserve dele (se s. 38)



Godkendelse (se s. 40)

Fejl	Årsag	Hjælp
Grebet går trægt	- Kartusche defekt, tilkalket	- Udskift kartusche
Armaturet drypper	- Defekt eller tilkalket kartusche	- Udskift kartusche
Omstillen virker ikke	- Aflejring	- Rens omskifteren / smør O-ringe
	- For lavt vandtryk	- Forøg vandtrykket
	- Defekt omstillen	- Udskift omstilleren
For lav varmtvandstemperatur. Ingen koldt vand. Vandvarmeren starter, når der åbnes for det kolde vand.	- Varmtvandsbegrænsningen er forkert indstillet	- Indstil varmtvandsbegrænsningen
	- Kryds-flow	- Udskift kartusche





Avisos de segurança

- ⚠ Durante a montagem devem ser utilizadas luvas de protecção, de modo a evitar ferimentos resultantes de entalamentos e de cortes.
- ⚠ O sistema de duche só pode ser utilizado para fins de higiene pessoal.
- ⚠ Grandes diferenças entre as pressões das águas quente e fria devem ser compensadas.

Avisos de montagem

- Antes da montagem deve-se controlar o produto relativamente a danos de transporte. Após a montagem não são aceites quaisquer danos de transporte ou de superfície.
- A misturadora deve ser instalada, purgada e testada de acordo com as normas em vigor.

Dados Técnicos

Pressão de funcionamento:	max. 1 MPa
Pressão de func. recomendada:	0,1 - 0,5 MPa
Pressão testada:	1,6 MPa
(1 MPa = 10 bar = 147 PSI)	
Temperatura da água quente:	max. 80 °C
Temp. água quente recomendada:	65 °C
Desinfecção térmica:	max. 70 °C / 4 min

10417000 / 17417XXX. Função anti-retorno e anti-vácuo

Este produto foi única e exclusivamente concebido para água potável!

As misturadoras Hansgrohe podem ser utilizadas com esquentadores (de controlo térmico ou hidráulico) desde que a pressão de utilização seja, no mínimo, de 0,15 MPa.

Descrição do símbolo



Não utilizar silicone que contenha ácido acético!



Afinação (ver página 33)

Misturadora monocomando equipada com limitador de temperatura (vide pág. 33). Em combinação com caldeira ou esquentador instantâneo o limitador de água quente não é recomendado.



Medidas (ver página 34)



Fluxograma (ver página 34)

- ① Saída do chuveiro
- ② Saída da banheira



Funcionamento (ver página 35)



Manutenção (ver página 36)

10417000 / 17417XXX: As válvulas anti-retorno devem ser verificadas regularmente de acordo com a DIN EN 1717 segundo os regulamentos nacionais ou regionais (pelo menos uma vez por ano).



Limpeza

Consultar a seguinte brochura sobre as recomendações de limpeza.



Peças de substituição (ver página 38)



Marca de controlo (ver página 40)

Falha	Causa	Solução
Misturadora perra	- Cartucho defeituoso, calcificado	- Substituir o cartucho
Misturadora a pingar	- Manga da esfera defeituosa	- Substituir o cartucho
Inversor não funciona	- Depósitos	- Limpar inversor / lubrificar vedantes em O
	- Pressão da água muito baixa	- Aumentar a pressão da água
	- Inversor defeituoso	- Substituir o inversor
Temperatura da água quente muito baixa, sem água fria. O esquentador dispara quando a água fria está seleccionada.	- O limitador de temperatura está incorrectamente colocado	- Regular o limitador de temperatura
	- Fluxo cruzado	- Substituir o cartucho





! Wskazówki bezpieczeństwa

- △ Aby uniknąć zranień, takich jak zgniecenia czy przecięcia, podczas montażu należy nosić rękawice.
- △ Pysznic może być używany tylko do kąpieli, higieny i czyszczenia ciała.
- △ Znaczne różnice ciśnień na dopływach ciepłej i zimnej wody muszą zostać wyrównane.

Wskazówki montażowe

- Przed montażem należy skontrolować produkt pod kątem szkód transportowych. Po montażu nie widać żadnych szkód transportowych ani szkód na powierzchni.
- Armatura musi być zamontowana, przepłukana i wypróbowana według obowiązujących norm.

Dane techniczne

Ciśnienie robocze:	maks. 1 MPa
Zalecane ciśnienie robocze:	0,1 - 0,5 MPa
Ciśnienie próbne:	1,6 MPa
(1 MPa = 10 bary = 147 PSI)	
Temperatura wody gorącej:	maks. 80 °C
Zalecana temperatura wody gorącej:	65 °C
Dezynfekcja termiczna:	maks. 70 °C / 4 min

10417000 / 17417XXX. Samoistnie zabezpieczony przed przepływem zrotnym

Produkt stworzono wyłącznie do wody pitnej!

Armatura Hansgrohe może być stosowana z przepływowymi podgrzewaczami wody sterowanymi hydraulicznie i termicznie w przypadku, gdy ciśnienie przepływu wynosi co najmniej 0,15 MPa.

Opis symbolu



Nie stosować silikonów zawierających kwas octowy!



Ustawianie (patrz strona 33)
Mieszacz jednouchwytowy z ogranicznikiem temperatury wody, ustawianie, patrz str. 33. Używanie ogranicznika temperatury wody w połączeniu z przepływowym podgrzewaczem wody nie jest zalecane.



Wymiary (patrz strona 34)



Schemat przepływu
(patrz strona 34)

- ① Odpływ prysznicy
- ② Odpływ wanny



Obsługa (patrz strona 35)



Konserwacja (patrz strona 36)
10417000 / 17417XXX: Zawory zrotne muszą być, według normy DIN EN 1717 na regionalnych warunkach, kontrolowane (przynajmniej raz w roku).



Czyszczenie

Zalecenie dotyczące pielęgnacji, patrz dołączona broszura.



Części serwisowe (patrz strona 38)



Znak jakości (patrz strona 40)

Usterka	Przyczyna	Pomoc
Uchwyt armatury pracuje z wysiłkiem	- Uszkodzony wkład, zakamieniony	- Wymiana wkładu
Armatura cieknie	- Uszkodzony wkład, osady	- Wymiana wkładu
Przetłacznik nie funkcjonuje	- Osady	- Wyczyścić przetłacznik / nasmarować o-ringi
	- Zbyt niskie ciśnienie wody	- Podnieść ciśnienie wody
	- Uszkodzony przetłacznik	- Wymienić przetłacznik
Za niska temperatura ciepłej wody, brak zimnej wody. Przepływowy podgrzewacz wody uruchamia się, gdy wybiera się zimną wodę.	- Niewłaściwe ustawienie ogranicznik ciepłej wody	- Ustawić ogranicznik ciepłej wody
	- Przepływ krzyżowy	- Wymiana wkładu



Montaż patrz strona 31



Bezpečnostní pokyny

- ⚠ Pro zabránění řezným zraněním a pohmožděninám je nutné při montáži nosit rukavice.
- ⚠ Produkt smí být používán pouze ke koupání a za účelem tělesné hygieny.
- ⚠ Je nutné vyrovnat velké rozdíly tlaku mezi přípoji studené a teplé vody.

Pokyny k montáži

- Před montáží je třeba produkt zkontrolovat, zda nebyl při transportu poškozen. Po zabudování nebudou uznány žádné škody způsobené transportem nebo poškození povrchu.
- Armatura se musí montovat, proplachovat a testovat podle platných norem.

Technické údaje

Provozní tlak:	max. 1 MPa
Doporučený provozní tlak:	0,1 - 0,5 MPa
Zkušební tlak:	1,6 MPa
(1 MPa = 10 bar = 147 PSI)	
Teplota horké vody:	max. 80 °C
Doporučená teplota horké vody:	65 °C
Teplná desinfekce:	max. 70 °C / 4 min

10417000 / 17417XXX. Vlastní jistiění proti zpětnému nasátí.

Výrobky Hansgrohe jsou vhodné pro přímý kontakt s pitnou vodou.

Armatury Hansgrohe je možno používat v kombinaci s hydraulicky a tepelně řízenými průtokovými ohřívači v případě, že tlak činí minimálně 0,15 MPa.

Popis symbolů



Nepoužívat silikon s obsahem kyseliny octové!



Nastavení (viz strana 33)

Páková baterie s omezením horké vody, seřízení viz. str. 33. Ve spojení s průtokovými ohřívači nedoporučujeme používat uzavěr teplé vody.



Rozměry (viz strana 34)



Diagram průtoku

(viz strana 34)

- ① Odtok sprchy
- ② Odtok vany



Ovládání (viz strana 35)



Údržba (viz strana 36)

10417000 / 17417XXX: Bezpečnostní zařízení musí být podle DIN EN 1717 pravidelně v souladu s národními nebo místními předpisy (DIN 1988) jednou ročně přezkoušena.



Čištění

Doporučení k čištění viz příložená brožura.



Servisní díly (viz strana 38)



Zkušební značka (viz strana 40)

Porucha	Příčina	Odstranění
Armatura jde ztěžka	- Kartuše je vadná, zanesená vodním kamenem	- Kartuši vyměnit
Armatura odkapává	- kartuše je vadná, usazeniny	- Kartuši vyměnit
Přepínač nefunguje	- Usazeniny	- Vyčistit přepínač/promazat o-kroužky
	- příliš malý tlak vody	- zvýšit tlak vody
	- přepínač defektní	- Přepínač vyměnit
nízká teplota teplé vody, žádná studená voda průtokový ohřívač naskočí, když se navolí studená voda	- Špatně nastavená zarážka pro teplou vodu	- Seřídit zarážku pro teplou vodu
	- Křížení toků	- Kartuši vyměnit



Montáž viz strana 31



! Bezpečnostné pokyny

- ⚠ Pri montáži musíte nosiť rukavice, aby ste predišli pomliaždeninám a rezným poraneniam.
- ⚠ Produkt sa smie používať len na kúpanie a telesnú hygienu.
- ⚠ Veľké rozdiely v tlaku medzi prípojkami studenej a teplej vody musia byť vyrovnané.

Pokyny pre montáž

- Pred montážou musíte produkt skontrolovať, či nebol počas transportu poškodený. Po zabudovaní nebudú uznané žiadne škody spôsobené transportom alebo poškodenia povrchu.
- Armatúra sa musí montovať, preplachovať a testovať podľa platných noriem.

Technické údaje

Prevádzkový tlak:	max. 1 MPa
Doporučený prevádzkový tlak:	0,1 - 0,5 MPa
Skúšobný tlak:	1,6 MPa
(1 MPa = 10 bar = 147 PSI)	
Teplota teplej vody:	max. 80 °C
Doporučená teplota teplej vody:	65 °C
Termická dezinfekcia:	max. 70 °C / 4 min

10417000 / 17417XXX. Vlastná poisťka proti spätnému nasatiu.

Výrobok je koncipovaný výhradne pre pitnú vodu!

Batérie Hansgrohe môžete používať v spojení s hydraulickými a tepelne ovládanými prietokovými ohrievačmi, ak je tlak minimálne 0,15 MPa.

Popis symbolov



Nepoužívať silikón s obsahom kyseliny octovej!



Nastavenie (viď strana 33)

Páková batéria s obmedzením teplej vody, nastavenie viď.str. 33. V spojení s prietokovými ohrievačmi sa uzáver teplej vody neodporúča.



Rozmery (viď strana 34)



Diagram prietoku

(viď strana 34)

- ① Odtok sprchy
- ② Odtok vane



Obsluha (viď strana 35)



Údržba (viď strana 36)

10417000 / 17417XXX: Bezpečnostné zariadenie musí byť podľa DIN EN 1717 pravidelne raz za rok preskúšané v súlade s národnými alebo miestnymi predpismi (DIN 1988).



Čistenie

Odporúčanie o čistení nájdete v priloženej brožúre.



Servisné diely (viď strana 38)



Osvedčenie o skúške (viď strana 40)

Porucha	Príčina	Pomoc
Armatúra "chodí" ťažko	- Kartuša je poškodená, vápenaté usadeniny	- Vymeniť kartušu
Z armatúry kvapká voda	- Chybná kartuša, usadeniny	- Vymeniť kartušu
Prepínač nefunguje	- Usadeniny	- Vyčistiť prepínač / namazať O krúžky
	- Príliš malý tlak vody	- Zvýšiť tlak vody
	- Prepínač defektný	- Prepínač vymeniť
Málo teplá voda, žiadna studená voda, prietokový ohrievač naskočí, keď sa navolí studená voda.	- Nesprávne nastavená záračka na teplú vodu	- Nastavenie záračky na teplú vodu
	- Kríženie tokov	- Vymeniť kartušu



Montáž viď strana 31



安全技巧

- △ 装配时为避免挤压和切割受伤，必须戴上手套。
- △ 淋浴系统只允许作为洗浴、卫生和洁身之用。
- △ 冷热水管间过大的压力差必须予以平衡。

安装提示

- 安装前必须检查产品是否受到运输损害。安装后将不认可运输损害或表面损伤。
- 必须按照现行的规定安装，冲洗和测试产品。

技术参数

工作压强:	最大 1 MPa
推荐工作压强:	0,1 - 0,5 MPa
测试压强:	1,6 MPa
(1 MPa = 10 bar = 147 PSI)	
热水温度:	最大 80° C
推荐热水温度:	65° C
热力消毒:	最大 70° C / 4 分钟

10417000 / 17417XXX. 自动防止回流

该产品专为饮用水设计！

如果水压达到0,15 MPa以上，汉斯格雅双手柄龙头可以和液压式或热控式连续流热水器一起使用。

符号说明



请勿使用含有乙酸的硅！



调节 (参见第 33 页)

带有热水控制器的单手柄龙头的调节方法，参见第 33 页。如果与即热式热水器一起使用，则不建议使用止热水装置。



大小 (参见第 34 页)



流量示意图

(参见第 34 页)

- ① 莲蓬头岔管
- ② 面盆岔管



操作 (参见第 35 页)



保养 (参见第 36 页)

10417000 / 17417XXX: 必须根据DIN EN 1717要求并根据国家或地方规定定期 (DIN 1988规定为一年一次) 检查安全装置的功能。



清洗

清洁建议参见附入的小册子。



备用零件 (参见第 38 页)



检验标记 (参见第 40 页)

问题	原因	补救
龙头不灵活	- 滤筒损坏, 结垢	- 更换滤筒
龙头滴水	- 滤筒损坏, 沉淀	- 更换滤筒
分流器不工作	- 沉积物	- 清洁分流器 / 给O形环上油
	- 水压过低	- 增加水压
	- 分流器损坏	- 更换分流器
热水温度过低, 没有冷水。选择冷水时, 热水器启动。	- 热水控制器设置错误	- 设置热水控制器
	- 交叉流动	- 更换滤筒



安装 参见第 31 页



Указания по технике безопасности

- Во время монтажа следует надеть перчатки во избежание прищемления и порезов.
- Изделие разрешается использовать только в гигиенических целях: для принятия ванны и личной гигиены.
- донного клапа. Перед установкой смесителя необходимо регулировочными кранами выровнять авление холодной и горячей воды при помощи вентмлей регулирующих подачу воды в квартиру.

Указания по монтажу

- Перед монтажом следует проверить изделие на предмет повреждений при перевозке. После монтажа претензии о возмещении ущерба за повреждения при перевозке или повреждения поверхностей не принимаются.
- Смеситель должен быть смонтирован по действующим нормам и в соответствии с настоящей инструкцией, проверен на герметичность и безупречность работы.

Технические данные

Рабочее давление:	не более 1 МПа
Рекомендуемое рабочее давление:	0,1 - 0,5 МПа
Давлени:	1,6 МПа
(1 МПа = 10 bar = 147 PSI)	
Температура горячей воды:	не более 80 °С
Рекомендуемая темп. гор. воды:	65 °С
Термическая дезинфекция:	не более 70 °С / 4 мин

10417000 / 17417XXX. укомплектован клапаном обратного тока воды

Изделие предназначено исключительно для питьевой воды!

Арматуры Hansgrohe могут использоваться в комбинации с проточными нагревателями с гидравлическим и термическим управлением, если давление истечения составляет не менее 0,15 МПа.

Неисправность	Причина	Устранение неисправности
Арматура работает с усилием	- Картридж неисправен, засорение накипью	- Замените картридж
Арматура протекает	- Картридж неисправен, отложения	- Замените картридж
Переключатель не работает	- отложения	- очистите переключатель / смажьте консистентной смазкой кольца круглого сечения
	- Слишком малое давление воды	- Увеличьте давление воды
	- Переключатель неисправен	- Замените переключатель
Слишком низкая температура горячей воды. Проточный нагреватель запускается при выборе холодной воды.	- Ограничение горячей воды отрегулировано неправильно	- Отрегулируйте ограничение горячей воды
	- Перекрестный поток	- Замените картридж

Описание символов



Не применяйте силикон, содержащий искусную кислоту.



Подгонка (см. стр. 33)
Однорычажный смеситель имеет ограничитель расхода горячей воды (см. Стр. 33: юстировка). В комбинации с проточными нагревателями не рекомендуется установка блокировка горячей воды!



Размеры (см. стр. 34)



Схема потока
(см. стр. 34)

- Отвод душа
- Отвод ванны



Эксплуатация (см. стр. 35)



Техническое обслуживание
(см. стр. 36)

10417000 / 17417XXX: Прокладка отвода должна осуществляться без нагрузки!



Очистка

Рекомендации по очистке см. в прилагаемой брошюре.



Комплект (см. стр. 38)



Знак технического контроля
(см. стр. 40)





Biztonsági utasítások

- △ A szerelésnél a zúzódások és vágási sérülések elkerülése érdekében kesztyűt kell viselni.
- △ A terméket csak fürdéshez, mosakodáshoz, és egészségügyi tisztálkodáshoz szabad használni.
- △ A hidegvíz- és a melegvíz-csatlakozások közötti nagy nyomáskülönbséget kikell egyenlíteni!

Szerelési utasítások

- A szerelés előtt ellenőrizni kell, hogy a terméknek nincs-e szállítási sérülése. Beépítés után a szállítási- vagy felületi sérüléseket nem ismerik el.
- A csaptelepet az érvényben lévő előírásoknak megfelelően kell felszerelni, átöblíteni és ellenőrizni.

Műszaki adatok

Üzemi nyomás:	max. 1 MPa
Ajánlott üzemi nyomás:	0,1 - 0,5 MPa
Nyomáspróba:	1,6 MPa
(1 MPa = 10 bar = 147 PSI)	
Forróvíz hőmérséklet:	max. 80 °C
Forróvíz javasolt hőmérséklete:	65 °C
Termikus fertőtlenítés:	max. 70 °C / 4 perc

10417000 / 17417XXX. Visszafolyás gátlóval

A terméket kizárólag ivóvízhez tervezték!

A Hansgrohe csaptelepek hidraulikus és termikus vezérlésű átfolyós melegítőkkal kapcsolatban is használhatóak, ha az átfolyó nyomás legalább 0,15 MPa.

Szimbólumok leírása



Ne használjon ecetsavtartalmú szilikon!



Beállítás (lásd a 33. oldalon)

Az egykaros, melegvíz-korlátozóval ellátott keverő csaptelep beállítását lásd a 33. oldalon. Az átfolyó rendszerű vízmelegítőknél nem ajánlott a melegvíz-korlátozó.

Méretet (lásd a 34. oldalon)



Átfolyási diagramm
(lásd a 34. oldalon)

- ① Zuhany lefolyója
- ② Kád lefolyója



Használat (lásd a 35. oldalon)



Karbantartás (lásd a 36. oldalon)

10417000 / 17417XXX: A biztonsági berendezések működését a DIN EN 1717 szerint rendszeresen, a nemzeti vagy helyi előírásoknak megfelelően (DIN 1988 évente egyszer) ellenőrizni kell.



Tisztítás

Az ajánlott tisztításhoz lásd a mellékelt brosúrát.



Tartozékok (lásd a 38. oldalon)



Vizsgajel (lásd a 40. oldalon)

Hiba	Ok	Megoldás
Nehezen nyitható a csap.	- A kerámiabetét meghibásodott, elvízkövesedett.	- A kerámiabetétet ki kell cserélni.
Csőpög a csap.	- A kerámiabetét meghibásodott, lerakódások	- A kerámiabetétet ki kell cserélni.
Az átállítás nem működik	- Lerakódások	- Váltószelepet tisztítani / O-gyűrűket zsírozni
	- Túl kicsi víznyomás	- Növelje a víznyomást
	- A kádváltó szelep hibás	- Az átállító cseréje
Túl alacsony melegvíz hőmérséklet, nincs hidegvíz. A hidegvíz kiválasztásakor beindul az átfolyós melegítő.	- A melegvíz szabályozó rosszul van beállítva.	- A melegvíz szabályozót újra be kell állítani.
	- Keresztfolyás	- A kerámiabetétet ki kell cserélni.



Szerelés lásd a 31. oldalon



Turvallisuushjeet

- Asennuksessa on käytettävä käsiineitä puristumien ja viiltojen aiheuttamien tapaturmien estämiseksi.
- Suihkujärjestelmää saa käyttää ainoastaan kylpy-, hygienia- ja puhdistustarkoituksiin.
- Suuret paine-erot kylmä- ja kuumavesiliitännöiden välillä on tasattava.

Asennusohjeet

- Ennen asennusta on tarkastettava tuotteen mahdolliset kuljetusvahingot. Asennuksen jälkeen kuljetus- ja pintavaurioita ei hyväksytä.
- Kaluste on asennettava, huuhdeltava ja tarkastettava voimassa olevien määräysten mukaisesti.

Tekniset tiedot

Käyttöpaine:	maks. 1 MPa
Suosittelut käyttöpaine:	0,1 - 0,5 MPa
Koestuspaine:	1,6 MPa
(1 MPa = 10 bar = 147 PSI)	
Kuuman veden lämpötila:	maks. 80 °C
Kuuman veden suosituslämpötila:	65 °C
Lämpödesinfektio:	maks. 70 °C / 4 min

10417000 / 17417XXX. Estää itsestään paluuvirtauksen

Tuote on suunniteltu käytettäväksi ainoastaan juomaveden kanssa!

Hansgrohe kalusteita voi käyttää hydraulisesti tai termisesti ohjattujen läpivirtauskuumentimien yhteydessä, jos virtauspaine on vähintään 0,15 MPa.

Merkin kuvaus



Älä käytä etikkahappopitoista silikonia!



Säätö (katso sivu 33)

Yksivipuinen sekoittaja lämpimän veden rajoituksella, katso säätö sivulta 33. Lämpimän veden rajoitusta ei suositella läpivirtauskuumentimen yhteydessä.



Mitat (katso sivu 34)



Virtausdiagrammi

(katso sivu 34)

- Suihkun lähtö
- Ammeen lähtö



Käyttö (katso sivu 35)



Huolto (katso sivu 36)

10417000 / 17417XXX: Turvalaitteiden toiminta on tarkastettava DIN EN 1717:n mukaisesti säännöllisin väliajoin kansallisten ja paikallisten määräysten mukaisesti (DIN 1988: kerran vuodessa).



Puhdistus

Katso puhdistussuositus mukana olevasta esitteestä.



Varaosat (katso sivu 38)



Koestusmerkki (katso sivu 40)

Häiriö

Syy

Toimenpide

Hana on raskaskäyttöinen	- Patruuna rikki, kalkkikerrostumia	- Vaihda patruuna
Hanasta tippuu vettä	- Patruuna rikki, kerrostumia	- Vaihda patruuna
Valitsin ei toimi	- kerrostumia	- Vaihtimen puhdistus / O-renkaiden rasvaus
	- Liian matala vedenpaine	- Lisää vedenpainetta
	- Valitsin rikki	- Vaihda valitsin
Lämminveden lämpötila liian alhainen, ei kylmää vettä.	- Lämminveden rajoitin väärin säädetty	- Säädä lämminveden rajoitin
Läpivirtauskuumentimen käynnistyy kylmää vettä otettaessa.	- Ristiinvirtaus	- Vaihda patruuna





! Säkerhetsanvisningar

- △ Handskar ska bäras under monteringsarbetet så att man kan undvika kläm- och skärskador gen. werden.
- △ Produkten får bara användas till kroppshygiene med bad och dusch.
- △ Stora tryckskillnader mellan anslutningarna för varmt och kallt vatten måste utjämnas.

Monteringsanvisningar

- Det måste undersökas om produkten har transportskador innan den monteras. Efter monteringen accepteras inga transport- eller ytskiktsskador.
- Armaturen måste installeras, genomspolas och testas enligt gällande föreskrifter.

Tekniska data

Driftstryck:	max. 1 MPa
Rek. driftstryck:	0,1 - 0,5 MPa
Tryck vid provtryckning:	1,6 MPa
(1 MPa = 10 bar = 147 PSI)	
Varmvattentemperatur:	max. 80 °C
Rek. varmvattentemp.:	65 °C
Termisk desinfektion:	max. 70 °C / 4 min

10417000 / 17417XXX. Självspärr mot återflöde

Produkten är enbart avsedd för dricksvatten!

Hansgrohe blandare kan användas tillsammans med hydrauliskt och termiskt styrda varmvattenberedare när flödestrycket uppgår till minst 0,15 MPa.

Symbolförklaring



Använd inte silikon som innehåller ättiksyra!



Justering (se sidan 33)

Enhandsblandare med varmvattenreglering, justering se sidan 33. Tillsammans med varmvattenberedare rekommenderas inte en varmvattenreglering.



Måtten (se sidan 34)



Flödesschema

(se sidan 34)

- ① Avlopp dusch
- ② Avlopp kar



Hantering (se sidan 35)



Skötsel (se sidan 36)

10417000 / 17417XXX: Enligt DIN EN 1717 måste säkerhetsanordningarnas funktion kontrolleras regelbundet och i överensstämmelse med nationella eller regionala bestämmelser (DIN 1988 en gång per år).



Rengöring

Se den medföljande broschyren för rengöringsrekommendation



Reservdelar (se sidan 38)



Testsigill (se sidan 40)

Störning	Orsak	Åtgärd
Blandare är trög	- Patron defekt, förkalkad	- Byt ut patron
Blandare droppar	- Patron defekt, avlagringar	- Byt ut patron
Omkopplare fungerar inte	- Avlagringar	- Rengör omkastare / smörj O-ringar
	- För lågt vattentryck	- Öka vattentrycket
	- Omkopplare defekt	- Byt ut omkopplare
För låg varmvattentemperatur, inget kallvatten. Varmvattenberedaren slår på när kallvatten väljs.	- Varmvattenreglering felaktigt inställd	- Ställ in varmvattenreglering
	- Korsflöde	- Byt ut patron





Saugumo technikos nurodymai

- ⚠ Apsaugai nuo užspaudimo ir įsijovimo montavimo metu mūvėkite pirštines.
- ⚠ Gaminys turi būti naudojamas tik maudymuisi, kūno higienai ir švarai palaikyti.
- ⚠ Turi būti išlyginti šalto ir karšto slėgio nelygumai.

Montavimo instrukcija

- Prieš montuojant būtina patikrinti, ar gaminys nebuvo pažeistas transportavimo metu. Sumontavus pretenzijos dėl transportavimo ir paviršiaus pažeidimų nepriimamos.
- Maišytuvas privalo būti montuojamas ir išbandomas pagal veikiančias normas ir šią instrukciją.

Techniniai duomenys

Darbinis slėgis: ne daugiau kaip 1 MPa
 Rekomenduojamas slėgis: 0,1 - 0,5 MPa
 Bandomasis slėgis: 1,6 MPa
 (1 MPa = 10 barų = 147 PSI)
 Karšto vandens temperatūra: ne daugiau kaip 80 °C
 Rekomenduojama karšto vandens temperatūra: 65 °C
 Terminis dezinfekavimas: ne daugiau kaip 70 °C / 4 min

10417000 / 17417XXX. Su atbuliniu vožtuvu

Produktas skirtas tik geriamajam vandeniui!

„Hansgrohe“ maišytuvai gali būti naudojami su hidrauliškai ir termiškai reguliuojamais momentiniais šildikliais, kai vandens slėgis mažesnis kaip 0,15 MPa.

Simbolio aprašymas



Nenaudokite silikono, kurio sudėtyje yra acto rūgšties!



Reguliavimas (žr. psl. 33)

Vienos rankenėlės maišytuvus turi karšto vandens ribotuvą (nustatymą žr. psl. 33). Naudojant momentinį šildiklį karšto vandens ribotuvus nerekomenduojamas.



Išmatavimai (žr. psl. 34)



Pralaidumo diagrama

(žr. psl. 34)

- ① Dušo išleidimas
- ② Vonios išleidimas



Eksploatacija (žr. psl. 35)



Techninis aptarnavimas

(žr. psl. 36)

10417000 / 17417XXX : Pagal DIN EN 1717 ir nacionalines arba regionines direktyvas reikia reguliariai tikrinti saugos įrangos veikimą (pagal DIN 1988 - kartą per metus).



Valymas

Valymo rekomendacijas žr. pridedamoje brošiūroje.



Atsarginės dalys (žr. psl. 38)



Bandymo pažyma (žr. psl. 40)



Gedimas	Priežastis	Priemonė
Sunkiai sukiojama rankenėlė	- Kasetė pažeista, užkalkėjusi	- Pakeisti kasetę
Maišytuvas praleidžia vandenį	- Kasetė pažeista, užkalkėjusi	- Pakeisti kasetę
Perjungėjas nefunkcionuoja	- Apnašos	- Išvalykite atsukimą/-sutepkite O-žiedus
	- Nepakankamas vandens spaudimas	- Pakelti vandens spaudimą
	- Pažeistas perjungėjas	- Pakeisti perjungėją
Per mažą karšto vandens temperatūrą, nėra šalto vandens.	- Neteisingai nustatytas karšto vandens ribotuvus	- Nustatyti karšto vandens ribotuvą
Momentinis pašildytojas pradeda veikti, kai naudojamas šalta vanduo	- Kryžminė srovė	- Pakeisti kasetę



Montavimas žr. psl. 31



Sigurnosne upute

-  Prilikom montaže se radi sprječavanja prignječenja i posjekotina moraju nositi rukavice.
-  Proizvod se smije primjenjivati samo za kupanje, tuširanje i osobnu higijenu.
-  Velika razlika u pritisku između vruće i hladne vode mora biti izbalansirana.

Upute za montažu

- Prije montaže mora se provjeriti je li proizvod oštećen prilikom transporta. Nakon ugradnje se ne priznaju nikakve reklamacije koje se odnose na površinska i transportna oštećenja.
- Cijevi moraju biti postavljene, isprane i testirane prema važećim normama.

Tehnički podaci

Najveći dopušteni tlak: tlak 1 MPa
 Preporučeni tlak: 0,1 - 0,5 MPa
 Probni tlak: 1,6 MPa
 (1 MPa = 10 bar = 147 PSI)
 Temperatura vruće vode: tlak 80 °C
 Preporučena temperatura vruće vode: 65 °C
 Termička dezinfekcija: tlak 70 °C / 4 min

10417000 / 17417XXX. Funkcije samo-čišćenja

Proizvod je koncipiran isključivo za pitku vodu!

Hansgrohe armature mogu se koristiti u kombinaciji sa hidraulički i termički kontroliranim protočnim bojlerima ukoliko tlak iznosi najmanje 0,15 MPa

Opis simbola



Nemojte koristiti silikon koji sadrži octenu kiselinu!



Regulacija (pogledaj stranicu 33)

Za namještanje jednoručnih miješalica s limiterom tople vode vidi str. 33. U kombinaciji s protočnim bojlerima nije preporučljiva primjena sustava za blokiranje dotoka tople vode.

Mjere (pogledaj stranicu 34)



Dijagram protoka (pogledaj stranicu 34)



- ① Ogranak tuš
- ② Ogranak kada



Upotreba (pogledaj stranicu 35)



Održavanje (pogledaj stranicu 36)

10417000 / 17417XXX: Ispravno funkcioniranje sigurnosnih elemenata se mora redovito provjeravati prema standardu DIN EN 1717 i sukladno važećim nacionalnim ili regionalnim propisima (DIN 1988 jednom godišnje).



Čišćenje

Upute za čišćenje nalaze se u priloženoj brošuri.



Rezervni dijelovi (pogledaj stranicu 38)



Oznaka testiranja (pogledaj stranicu 40)

Greška	Uzrok	Otklanjanje
Ručica se zaglavila	- Neispravan uložak Taloženje kamenca	- Zamijenite uložak
Slavina kaplje	- Neispravan uložak, naslage kamenca	- Zamijenite uložak
Selektor ne radi	- Naslage	- Čišćenje selektora i podmazivanje O-prstenova
	- Prenizak tlak vode	- Povećajte tlak vode
	- Selektor je neispravan	- Zamijenite selektor
Preniska temperatura vruće vode, nedostatak hladne vode. Protočni bojler se pali pri podešenoj funkciji za protok hladne vode	- Limiter vruće vode nije dobro podešen	- Podesite limiter vruće vode
	- Križni tok vode	- Zamijenite uložak



Sastavljanje pogledaj stranicu 31



⚠ Güvenlik uyarıları

- ⚠ Montaj esnasında ezilme ve kesilme gibi yaralanmaları önlemek için eldiven kullanılmalıdır.
- ⚠ Duş sistemi yalnızca banyo, hijyen ve beden temizliği amaçları doğrultusunda kullanılabilir.
- ⚠ Sıcak ve soğuk su bağlantıları arasında büyük basınç farklılıkları varsa, bu basınç farklılıklarının dengelenmesi gerekir.

Montaj açıklamaları

- Montaj işleminden önce ürün nakliye hasarları yönünden kontrol edilmelidir. Montaj işleminden sonra nakliye veya yüzey hasarları için sorumluluk üstlenilmemektedir.
- Batarya monte edilmeli, geçerli normlardan sonra akis testi yapılmalıdır.

Teknik bilgiler

İşletme basıncı:	azami 1 MPa
Tavsiye edilen işletme basıncı:	0,1 - 0,5 MPa
Kontrol basıncı:	1,6 MPa
(1 MPa = 10 bar = 147 PSI)	
Sıcak su sıcaklığı:	azami 80 °C
Tavsiye edilen su ısıtı:	65 °C
Termik dezenfeksiyon:	azami 70 °C / 4 dak

10417000 / 17417XXX. Geri emme önleyici

Ürün sadece şebeke suyu için tasarlanmıştır!

Hansgrohe bataryaları, akış basıncı en az 0,15 MPa olursa hidrolik ve termik kumandalı şofbenlerle bağlantılı olarak kullanılabilir.

Simge açıklaması



Asetik asit içeren silikon kullanmayın!



Ayarlama (Bakınız sayfa 33)

Sıcak su sınırlayıcı özelliğine sahip tek kollu bataryanın ayarlanması için 33. sayfaya bakınız. Bir sürekli akışlı su ısıtıcısı ile birlikte kullanılırsa sıcak su sınırlayıcısı önerilmez.



Ölçüleri (Bakınız sayfa 34)



Akış diyagramı (Bakınız sayfa 34)

- ① Su püskürtücü çıkışı
- ② Tekne çıkışı



Kullanımı (Bakınız sayfa 35)



Bakım (Bakınız sayfa 36)

10417000 / 17417XXX: Emniyet tertibatları DIN EN 1717 uyarınca düzenli olarak ulusal veya bölgesel yönetmeliklere göre (DIN 1988 uyarınca yılda bir kez), işlev yönünden kontrol edilmelidir.



Temizleme

Temizlik önerisi için birlikte verilen broşüre bakınız.



Yedek Parçalar (Bakınız sayfa 38)



Kontrol işareti (Bakınız sayfa 40)

arıza	sebebi	yardım
Batarya kullanımı ağırlaşıyor	- Kartuş Bozulmuş ve kireçlenmiş olabilir	- Kartuşu değiştirin
Batarya su damlatıyor	- Kartuş arızalı, kireçlenmiş	- Kartuşu değiştirin
Divertör çalışmıyor	- Çökelmeler	- Dönüştürücüyü temizleme / O ringleri yağlama
	- Su basıncı düşük	- Su basıncını artırın
	- Divertör arızalı	- Divertörü değiştirin
Sıcak su sıcaklığı çok düşük, soğuk su yok. Soğuk su seçilince şofben çalışmaya başlıyor.	- Isı limitleyici düzgün çalışmıyor	- Isı limitleyiciyi yeniden ayarlayın
	- Çapraz akış	- Kartuşu değiştirin





Instrucțiuni de siguranță

- ⚠ La montare utilizați mănuși pentru evitarea contuziunilor și tăierii mâinilor.
- ⚠ Sistemul de duș poate fi utilizat doar pentru spălarea, menținerea igienei și curățarea corpului.
- ⚠ Diferențele de presiune mari între alimentarea cu apă rece și apă caldă trebuie echilibrate.

Instrucțiuni de montare

- Înainte de instalare verificați, dacă produsul prezintă deteriorări de transport. După instalare garanția nu acoperă deteriorările de transport și cele de suprafață.
- Bateria trebuie montată, clătită și verificată conform normelor în vigoare.

Date tehnice

Presiune de funcționare:	max. 1 MPa
Presiune de funcționare recomandată:	0,1 - 0,5 MPa
Presiune de verificare:	1,6 MPa
(1 MPa = 10 bar = 147 PSI)	
Temperatura apei calde:	max. 80 °C
Temperatura recomandată a apei calde:	65 °C
Dezinfecție termică:	max. 70 °C / 4 min

10417000 / 17417XXX. Asigurat contra scurgere înapoi

Produsul este destinat exclusiv pentru apă potabilă.

Bateriile Hansgrohe pot fi utilizate cu boiler instant cu comandă termică sau hidraulică dacă presiunea apei de alimentare este de min. 0,15 MPa.

Descrierea simbolurilor



Nu utilizați silicon cu conținut de acid acetic!



Reglare (vezi pag. 33)

Baterie monocomadă cu limitarea apei calde, pentru reglare vezi pag. 33. Dacă conectați bateria la un boiler instant nu vă recomandăm instalarea unui opritor de apă caldă.

Dimensiuni (vezi pag. 34)



Diagrama de debit (vezi pag. 34)

- ① Orificiu de scurgere duș
- ② Orificiu de scurgere vană



Utilizare (vezi pag. 35)



Întreținere (vezi pag. 36)

10417000 / 17417XXX: Dispozitivele de siguranță trebuie verificate regulat conform DIN EN 1717 și în conformitate cu reglementările naționale și regionale (o dată pe an conform DIN 1988).



Curățare

Pentru recomandările referitoare la curățare vezi broșura alăturată.



Piese de schimb (vezi pag. 38)



Certificat de testare (vezi pag. 40)

Deranjament	Cauza	Măsurile de remediere
Bateria se mișcă dificil	- Cartuș defect din cauza depunerilor de calcar	- Schimbați cartușul.
Bateria picură	- Cartuș defect din cauza depunerilor	- Schimbați cartușul.
Cartușul nu funcționează.	- Depuneri	- Curățați inversorul / ungeți inelele O
	- Presiune apă prea mică	- Măriți presiunea de apă
	- Cartuș defect	- Schimbați cartușul.
Temperatura apei este prea mică, nu este apă rece. Boilerul instant pornește când se dă drumul la apa rece	- Limitarea temperaturii apei calde setată incorect.	- Setați limitarea temperaturii apei calde.
	- Curgere încrucișată (apa rece în intră în conducta de apă caldă și invers)	- Schimbați cartușul.



Montare vezi pag. 31



⚠ Υποδείξεις ασφαλείας

- ⚠ Για να αποφύγετε τραυματισμούς κατά τη συναρμολόγηση πρέπει να φοράτε γάντια.
- ⚠ Το προϊόν επιτρέπεται να χρησιμοποιείται μόνο σαν μέσο λουτρού, υγιεινής και καθαρισμού του σώματος.
- ⚠ Οι διαφορές της πίεσης μεταξύ της σύνδεσης κρύου και ζεστού νερού θα πρέπει να αντισταθμίζονται.

Οδηγίες συναρμολόγησης

- Πριν τη συναρμολόγηση πρέπει να εξεταστεί το προϊόν για ζημιές μεταφοράς. Μετά την εγκατάσταση δεν αναγνωρίζονται ζημιές από τη μεταφορά ή επιφανειακές ζημιές.
- Η μπαταρία πρέπει να τοποθετηθεί, να πλυθεί και να ελεγχθεί με βάση τους ισχύοντες κανόνες υδραυλικής τέχνης

Τεχνικά Χαρακτηριστικά

Λειτουργία πίεσης:	έως 1 MPa
Συνιστώμενη λειτουργία πίεσης:	0,1 - 0,5 MPa
Πίεση ελέγχου:	1,6 MPa
(1 MPa = 10 bar = 147 PSI)	
Θερμοκρασία ζεστού νερού:	έως 80 °C
Συνιστώμενη θερμοκρασία ζεστού νερού:	65 °C
Θερμική απολύμανση:	έως 70 °C / 4 min

10417000 / 17417XXX. Περιλαμβάνει βαλβίδα αντιπυροφής.

Το προϊόν έχει σχεδιαστεί αποκλειστικά για πόσιμο νερό!

Οι βάνες Hansgrohe μπορούν να συνδυαστούν με ταχυθερμοσίφωνες υδραυλικού και θερμικού ελέγχου, όταν η πίεση ροής αριθμεί τουλάχιστον 0,15 MPa.

Περιγραφή συμβόλων



Μην χρησιμοποιείτε σιλικόνη που περιέχει οξικό οξύ!



Ρύθμιση (βλ. σελίδα 33)

Για να προσαρμόσετε το δοσομετρητή ζεστού νερού σε αναμεικτικές μπαταρίες, παρακαλούμε δείτε τη ρύθμιση στη σελ. 33. Δεν συνιστάται η διάταξη φραγής ζεστού νερού σε συνδυασμό με ταχυθερμοσίφωνα.



Διαστάσεις (βλ. σελίδα 34)



Διάγραμμα ροής (βλ. σελίδα 34)

- ① Εξοδος ντους
- ② Εξοδος μπανιέρας



Χειρισμός (βλ. σελίδα 35)



Συντήρηση (βλ. σελίδα 36)

10417000 / 17417XXX: Οι διατάξεις ασφαλείας πρέπει να ελέγχονται σύμφωνα με το DIN EN 1717 τακτικά σύμφωνα με τις εθνικές ή τοπικές διατάξεις (DIN 1988 μία φορά τον χρόνο) ως προς τη λειτουργία τους.



Καθαρισμός

Για οδηγίες καθαρισμού βλ.επε συνημμένο ενημερωτικό φυλλάδιο.



Ανταλλακτικά (βλ. σελίδα 38)





Σήμα ελέγχου (βλ. σελίδα 40)

Βλάβη	Αιτία	Διόρθωση
Σκληρή μπαταρία (μείκτης)	- Ελαττωματικό φυσίγγιο, άλατα	- Αλλαγή φυσιγγίου
Η μπαταρία στάζει	- Ελαττωματικό φυσίγγιο, καθιζήσεις	- Αλλαγή φυσιγγίου
Ο διακόπτης επιλογής δεν λειτουργεί	- Άλατα	- Καθαρίστε τον ρυθμιστή νερού / λιπάνετε τους στεγανωτικούς δακτυλίους
	- Ανεπαρκής πίεση νερού	- Αυξήστε την πίεση του νερού
	- Βλάβη στο διακόπτη επιλογής	- Αλλάξτε το διακόπτη επιλογής
Χαμηλή θερμοκρασία ζεστού νερού, καθόλου κρύο νερό. Ο ταχυθερμοσίφωνα ενεργοποιείται, όταν επιλέγεται το κρύο νερό.	- Λάθος ρύθμιση της περιοριστικής διάταξης ζεστού νερού	- Ρυθμίστε την περιοριστική διάταξη του ζεστού νερού
	- Σταυροειδής ροή	- Αλλαγή φυσιγγίου





Varnostna opozorila

-  Pri montaži je treba nositi rokavice, da se preprečijo poškodbe zaradi zmečkanja ali urezov.
-  Ta izdelek se sme uporabljati le z namenom umivanja, vzdrževanja higiene in telesne nege.
-  Velike razlike v tlaku med priključkom za mrzlo in priključkom za toplo vodo je potrebno izravnati.

Instructions pour le montage

- Pred montažo je treba izdelek preveriti glede morebitnih transportnih poškodb. Po vgradnji transportne ali površinske poškodbe ne bodo več priznane.
- Armaturo je potrebno montirati, splakniti in testirati v skladu z veljavnimi predpisi.

Tehnični podatki

Delovni tlak:	maks. 1 MPa
Priporočeni delovni tlak:	0,1 - 0,5 MPa
Preskusni tlak:	1,6 MPa
(1 MPa = 10 bar = 147 PSI)	
Temperatura tople vode:	maks. 80 °C
Priporočena temperatura tople vode:	65 °C
Termična dezinfekcija:	maks. 70 °C / 4 min

10417000 / 17417XXX. Zaščita proti povratnemu toku

Proizvod je zasnovan izključno za sanitarno vodo!

Armature Hansgrohe lahko uporabljate v povezavi s hidravlično in termično uravnavanimi pretočnimi grelniki, če je pretočni tlak najmanj 0,15 MPa.

Opis simbola



Ne smete uporabiti silikona, ki vsebuje očetno kislino!



Justiranje (glejte stran 33)

Enoročne mešalne baterije z omejevalnikom tople vode, za justiranje glejte stran 33. V povezavi s pretočnimi grelniki zapora tople vode ni priporočljiva.



Mere (glejte stran 34)



Diagram pretoka

(glejte stran 34)

- ① Odvod prhe
- ② Odvod banje



Upravljanje (glejte stran 35)



Vzdrževanje (glejte stran 36)

10417000 / 17417XXX: Funkcije varnostnih priprav je treba po DIN EN 1717 redno preverjati v skladu z nacionalnimi ali regionalnimi predpisi (DIN 1988 enkrat letno).



Čiščenje

Priporočilo za čiščenje glejte v priloženi brošuri.



Rezervni deli (glejte stran 38)



Preskusni znak (glejte stran 40)

Napaka

Vzrok

Pomoč

Težko premikanje armature	- Pokvarjen vložek, poapneno	- Zamenjajte vložek
Iz armature kaplja	- Pokvarjen vložek, usedline	- Zamenjajte vložek
Preklopnik ne deluje	- Obloge	- Očistite premičnik / namastite obročno tesnilo
	- Prenizek vodni tlak	- Povečajte vodni tlak
	- Preklopnik je pokvarjen	- Zamenjajte preklopnik
Prenizka temperatura tople vode, ni mrzle vode. Pretočni grelnik se sproži, kadar izberete mrzlo vodo.	- Omejevalnik tople vode ni pravilno nastavljen	- Nastavite omejevalnik tople vode
	- Križni tok	- Zamenjajte vložek



Montaža Glejte stran 31.



⚠️ Ohutusjuhised

- △ Kandke paigaldamisel muljumis- ja löikevigastuste vältimiseks kindaid.
- △ Toodet tohib kasutada ainult pesemis-, hügieeni- ja kehahüvastamiseesmärkidel.
- △ Kui külma ja kuuma vee ühenduste surve on väga erinev, tuleb need tasakaalustada.

Paigaldamisjuhised

- Enne paigaldamist tuleb toodet kontrollida transpordikahjustuste osas. Pärast paigaldamist ei tunnustata enam transpordi- või pinnakahjustuste kaebuseid.
- Seadmestiku paigaldamine, läbipesu ja kontrollimine peab toimuma vastavalt kehtivatele normidele.

Tehnilised andmed

Töörõhk	maks. 1 MPa
Soovitav töörõhk:	0,1 - 0,5 MPa
Kontrollsurve:	1,6 MPa
(1 MPa = 10 baari = 147 PSI)	
Kuuma vee temperatuur:	maks. 80 °C
Soovitav kuuma vee temperatuur:	65 °C
Termiline desinfitatsioon:	maks. 70 °C / 4 min

10417000 / 17417XXX. Tagasivooluklapp

Toode on ette nähtud eranditult joogivee jaoks!

Hansgrohe segisteid võib kasutada koos hüdrauliliselt ja termiliselt juhitavate boileritega, kui vee surve on vähemalt 0,15 MPa.

Sümbolite kirjeldus



Ärge kasutage äädikhapet sisaldavat silikooni!



Reguleerimine (vt lk 33)

Ühe juhtkangiga segisti kuuma vee piiraja reguleerimise kohta vt lk 33. Läbivoolu boilerite puhul pole reguleerimine soovitatav.



Mõõtude (vt lk 34)



Läbivooludiagramm (vt lk 34)

- ① Duši väljund
- ② Vanni väljund



Kasutamine (vt lk 35)



Hoolitus (vt lk 36)

10417000 / 17417XXX:
Ohutusseadeldiste toimimist tuleb regulaarselt kontrollida, vastavalt standardile DIN EN 1717 riiklike või piirkondlike määrustega kooskõlas kontrollida (standardi DIN 1988 puhul üks kord aastas).



Puhastamine

Puhastussoovitusi vt kaasasolevast brošüürist.



Varuosad (vt lk 38)



Kontrollsertifikaat (vt lk 40)

Rike	Põhjus	Lahendus
Segisti käib raskelt	- Tööelement on katkine, lubjastunud	- Vahetage tööelement
Segisti tilgub	- Tööelement on katkine, sete	- Vahetage tööelement
Ümberlülit ei tööta	- Setted	- Ümberlülit puhastamine / O-tihendite määrimine
	- Vee surve liiga madal	- Tõstke vee survet
	- Ümberlülit defektne	- Zamenajate preklonnik
Liiga madal sooja vee temperatuur, külma vett pole. Läbivoolu boiler hakkab tööle, kui on valitud külm vesi.	- Kuuma vee piirang valesti seatud	- Seadke kuuma vee piirang
	- Ristvool	- Vahetage tööelement





Drošības norādes

- △ Montāžas laikā, lai izvairītos no saspiedumiem un iegriezumiem, nepieciešams nēsāt cimdus.
- △ Šo produktu drīkst izmantot tikai, lai mazgātos, higiēnai un ķermeņa tīrīšanai.
- △ Jāizlīdzina spiediena atšķirības starp aukstā un karstā ūdens pievadiem.

Norādījumi montāžai

- Pirms montāžas nepieciešams pārbaudīt, vai produktam transportēšanas laikā nav radušies bojājumi. Pēc iebūvēšanas bojājumi, kas radušies transportēšanas laikā, vai virsmas bojājumi netiek atzīti.
- Jaucējkrāns jāmontē, jāskalo un jāpārbauda atbilstoši spēkā esošajām normām.

Tehniskie dati

Darba spiediens:	maks. 1 MPa
Ieteicamais darba spiediens:	0,1 - 0,5 MPa
Pārbaudes spiediens:	1,6 MPa
(1 MPa = 10 bar = 147 PSI)	
Karstā ūdens temperatūra:	maks. 80 °C
Ieteicamā karstā ūdens temperatūra:	65 °C
Termiskā dezinfekcija :	maks. 70 °C / 4 min

10417000 / 17417XXX. Drošības vārsts

Izstrādājums ir paredzēts tikai dzeramajam ūdenim!

Hansgrohe jaucējkrānus var izmantot kombinācijā ar hidrauliski un termiski vadāmiem caurteces sildītājiem, ja plūsmas spiediens ir vismaz 0,15 MPa.

Simbolu nozīme



Neizmantojiet silikonu, kas satur etiķskābi!



Ieregulēšana (skat. 33. lpp.)

Viensvirs jaucējkrāns ar siltā ūdens ierobežošanu, ieregulēšanu skat. 33. lpp. Kombinācijā ar caurteces sildītāju karstā ūdens ierobežošana nav ieteicama.



Izmērus (skat. 34. lpp.)



Caurplūdes diagramma (skat. 34. lpp.)

- ① Dušas izeja
- ② Vannas izeja



Lietošana (skat. 35. lpp.)



Apkope (skat. 36. lpp.)

10417000 / 17417XXX: Drošības iestatījumu funkcionalitāte ir jāpārbauda regulāri atbilstoši DIN EN 1717 un saskaņā ar valsts vai reģionālajiem noteikumiem (saskaņā ar DIN 1988 vienreiz gadā).



Tīrīšana

Ieteikums tīrīšanai skatiet pievienotajā brošūrā.



Rezerves daļas (skat. 38. lpp.)



Pārbaudes zīme (skat. 40. lpp.)

Traucējums	Iemesls	Bojājumu novēršana
Jaucējkrāns smagi grozāms	- Bojāta kartuša, aizkaļķojusies	- Nomainīt kartušu
Jaucējkrāns pil	- Bojāta kartuša, nogulsnes	- Nomainīt kartušu
Pārslēdzējs nestrādā	- Nogulsnes	- Tīriet pārslēdzēju / eļļojiet blīvējošos gredzenus
	- Nepietiekams ūdens spiediens	- Paaugstināt ūdens spiedienu
	- Bojāts pārslēdzējs	- Nomainīt pārslēdzēju
Pārāk zema ūdens temperatūra, nav aukstā ūdens, izvēloties auksto ūdeni, sāk darboties caurteces sildītājs	- Nepareizi noregulāta karstā ūdens bloķēšana	- Noregulēt karstā ūdens ierobežošanu
	- Ūdens sajaukšanās	- Nomainīt kartušu



Montāža skat. 31. lpp.



! Sigurnosne napomene

- ⚠ Prilikom montaže se radi sprečavanja prignječenja i posekotina moraju nositi rukavice.
- ⚠ Proizvod sme da se koristi samo za kupanje, tuširanje i ličnu higijenu.
- ⚠ Velika razlika u pritisku između vruće i hladne vode mora biti izbalansirana.

Instrukcije za montažu

- Pre montaže se mora proveriti da li je proizvod oštećen pri transportu. Nakon ugradnje se ne priznaju nikakve reklamacije koje se odnose na površinska i transportna oštećenja.
- Armatura mora biti postavljena, isprana i testirana prema važećim normama.

Tehnički podaci

Radni pritisak:	maks. 1 MPa
Preporučeni radni pritisak:	0,1 - 0,5 MPa
Probni pritisak:	1,6 MPa
(1 MPa = 10 bar = 147 PSI)	
Temperatura vruće vode:	maks. 80 °C
Preporučena temperatura vruće vode:	65 °C
Termička dezinfekcija:	maks. 70 °C / 4 min

10417000 / 17417XXX. Zaštita od povratnog toka

Proizvod je koncipiran isključivo za pijaću vodu!

Hansgrohe armature se mogu koristiti u kombinaciji s hidraulički i termički kontrolisanim protočnim bojlerima ukoliko pritisak iznosi najmanje 0,15 MPa.

Opis simbola



Nemojte koristiti silikon koji sadrži sirćetnu kiselinu!



Podešavanje (vidi stranu 33)

Za podešavanje jednoručnih mešača sa ograničivačem tople vode vidi str. 33. U kombinaciji sa protočnim bojlerima ne preporučuje se primena sistema za blokiranje dotoka tople vode.

Mere (vidi stranu 34)



Dijagram protoka (vidi stranu 34)

- ① Ogranak tuš
- ② Ogranak kada



Rukovanje (vidi stranu 35)



Održavanje (vidi stranu 36)

10417000 / 17417XXX: Ispravno funkcionisanje bezbednosnih elemenata se mora redovno proveravati prema standardu DIN EN 1717 i u skladu s važećim nacionalnim ili regionalnim propisima (DIN 1988 jednom godišnje).



Čišćenje

Preporuke za čišćenje možete naći u priloženoj brošuri.



Rezervni delovi (vidi stranu 38)



Ispitni znak (vidi stranu 40)

Smetnja	Uzrok	Pomoć
Ručica se zaglavila	- Neispravna kartuša, nataloženi kamenac	- Zamenite kartušu
Slavina kaplje	- Neispravna kartuša, naslage kamenca	- Zamenite kartušu
Preusmerivač ne radi	- Naslage	- Čišćenje preusmerivača i podmazivanje O-prstenova
	- Prenizak pritisak vode	- Povećajte pritisak vode
	- Preusmerivač je neispravan	- Zamenite preusmerivač
Preiska temperatura tople vode, nema hladne vode. Protočni bojler se pali iako je puštena hladna voda.	- Ograničivač vruće vode nije dobro podešen	- Podesite ograničivač vruće vode
	- Ukršteni tok vode	- Zamenite kartušu





Sikkerhetshenvisninger

- △ Bruk hansker under montasjen for å unngå klem- og kuttskader.
- △ Dusjsystemet skal kun brukes for bade-, hygiene- og kroppshygiene.
- △ Store trykkdifferanser mellom kaldt- og varmtvannstilkoblinger skal utlignes.

Montagehenvisninger

- Før montasjen skal produktet sjekkes for transportskader. Etter monteringen aksepteres ikke noen transport- eller overflateskader.
- Armaturen skal monteres, spyles og sjekkes iht. gyldige standarder.

Tekniske data

Driftstrykk	maks. 1 MPa
Anbefalt driftstrykk:	0,1 - 0,5 MPa
Prøvetrykk	1,6 MPa
(1 MPa = 10 bar = 147 PSI)	
Varmtvannstemperatur	maks. 80 °C
Anbefalt temperatur for varmt vann	65 °C
Termisk desinfisering:	maks. 70 °C / 4 min

10417000 / 17417XXX. Egensikker mot tilbakeflyt

Produktet er utelukkende designet for drikkevann!

Armaturer fra Hansgrohe kan brukes sammen med hydraulisk og termisk styrte gjennomstrømningsovner når gjennomstrømningstrykket er på minst 0,15 MPa.

Symbolbeskrivelse

 Ikke bruk silikon som inneholder eddiksyre!

 **Justering** (se side 33)

Enhåndblandebatteri med varmtvannsbegrensning. For justering se side 33. I forbindelse med en gjennomstrømningsovner er det ikke anbefalt med varmtvannsbegrensning.

Mål (se side 34)



Gjennomstrømningsdiagram
(se side 34)

- ① Utgang dusj
- ② Utgang kar



Betjening (se side 35)



Vedlikehold (se side 36)

10417000 / 17417XXX: Funksjonen til sikkerhetsinnretninger skal kontrolleres iht. DIN EN 1717 og i samsvar med de nasjonale og lokale forskrifter, sjekkes regelmessig (DIN 1988 en gang i året).



Rengjøring

Se vedlagt brosjyre for rengjøringsanbefalinger.



Serviceleder (se side 38)



Prøvemerket (se side 40)

Feil	Årsak	Feilrettelse
Armatyr ikke lett bevegelig	- Kartusj defekt, forkalkning	- Kartusj byttes
Armatyr drypper	- Kartusj defekt, avleiringer	- Kartusj byttes
Omstiller fungerer ikke	- Avleiringer	- Rengjøre omstiller / smøre O-ringer
	- For lavt vanntrykk	- Øke vanntrykk
	- Omstiller defekt	- Omstiller byttes
For lav varmtvannstemperatur, ikke noe kaldtvann.	- Varmtvannsbegrensning er feil innstilt	- Varmtvannsbegrensning innstilles
Gjennomstrømningsovner slår seg på når det velges kaldt vann.	- Krysstrømning	- Kartusj byttes



Montasje se side 31



Указания за безопасност

- △ При монтажа трябва да се носят ръкавици, за да се избегнат наранявания поради притискане или порязване.
- △ Позволено е използването на продукта само за къпане, хигиена и цели на почистване на тялото.
- △ Големите разлики в налягането между изводите за студената и топлата вода трябва да се изравняват.

Указания за монтаж

- Преди монтажа продуктът трябва да се провери за транспортни щети. След монтажа не се признават транспортни или повърхностни щети.
- Арматурата трябва да се монтира, промие и провери в съответствие с валидните норми.

Технически данни

Работно налягане: макс. 1 МПа
 Препоръчително работно налягане: 0,1 - 0,5 МПа
 Контролно налягане: 1,6 МПа
 (1 МПа = 10 bar = 147 PSI)
 Температура на горещата вода: макс. 80 °C
 Препоръчителна температура на горещата вода: 65 °C
 Термична дезинфекция: макс. 70 °C / 4 мин
 10417000 / 17417XXX. Самозащитен против обратно изтичане

Продуктът е разработен само за питейна вода!

Арматурите на Hansgrohe могат да се използват във връзка с хидравлично и термично управляеми проточни нагреватели, ако хидравличното налягане е минимум 0,15 МПа.

Описание на символите



Не използвайте силикон, съдържащ оцетна киселина!



Юстиране (вижте стр. 33)

Смесител с една ръкохватка с ограничител за топлата вода, юстирането вижте на стр. 33. Във връзка с проточни нагреватели не се препоръчва блокировка за топлата вода.

Размери (вижте стр. 34)



Диаграма на потока (вижте стр. 34)

- ① Изход разпръсквател
- ② Извод вана



Обслужване (вижте стр. 35)



Поддръжка (вижте стр. 36)
 10417000 / 17417XXX: Съгласно DIN EN 1717 функционирането на предпазните приспособления трябва да се проверява на редовно в съответствие с националните или регионални изисквания (DIN 1988 веднъж годишно).



Почистване

Вижте препоръките при почистване от приложената брошура.



Сервизни части (вижте стр. 38)



Контролен знак (вижте стр. 40)

Неизправност	Причина	Помощ
Трудно подвижна арматура	- Дефектна гилза, покрита с варовик	- Сменете гилзата
Арматурата капе	- Дефектна гилза, отлагания	- Сменете гилзата
Превключвателят не функционира	- Отлагания	- Почистете превключвателя / Смажете O-образните пръстени
	- Твърде малко налягане на водата	- Повишаване на налягането на водата
	- Дефектен превключвател	- Сменете превключвателя
Твърде ниска температура на топлата вода, няма студена вода.	- Ограничението за топлата вода е грушно настроено	- Настройте ограничението за топлата вода
	- Проточният нагревател се задейства, когато се избере студена вода	- Кръстосване на потока



Монтаж вижте стр. 31



Udhëzime sigurie

- △ Për të evituar lëndimet e pickimeve ose të prerjeve gjatë procesit të montimit duhet që të vishni doreza.
- △ Produkti duhet të përdoret vetëm qëllimet e banjave, të higjienës dhe të larjes së trupit.
- △ Ndryshimet e mëdha të presionit mes lidhjeve të ujit të ftohtë dhe atij të ngrohtë duhen ekuilibruar.

Udhëzime për montimin

- Përpara montimit duhet që produkti të kontrollohet për dëmtime nga transporti. Pas instalimit nuk do të njihet asnjë dëmtim nga transporti ose dëmtim i sipërfaqes.
- Armatura duhet montuar, shpërlarë dhe kontrolluar në bazë të normave të vlefshme.

Të dhëna teknike

Presioni gjatë punës	maks. 1 MPa
Presioni i rekomanduar:	0,1 - 0,5 MPa
Presioni për provë:	1,6 MPa
(1 MPa = 10 bar = 147 PSI)	
Temperatura e ujit të ngrohtë	maks. 80 °C
Temperatura e rekomanduar e ujit të ngrohtë:	65 °C
Dezinfektim Termik:	maks. 70 °C / 4 min

10417000 / 17417XXX. Siguresa kundër rrjedhjes në drejtim të kundërt

Produkti është projektuar ekskluzivisht për ujë të pijshëm!

Armaturat e Hansgrohe mund të përdoren në kombinim me ngrohës elektrikë të ujit të drejtuar në mënyrë hidraulike ose termike nëse presioni i rrjedhjes është minimumi 0,15 MPa.

Përshkrimi i simbolit



Mos përdorni silikon që në përbërje ka acid acetik.



Justimi (shih faqen 33)

Rubinet me ujë të përzier me kufizim të ujit të ngrohtë, justimi shih faqen 33. Në kombinim me ngrohësit elektrikë të ujit nuk rekomandohet bllokada e ujit të ngrohtë.



Përmasat (shih faqen 34)



Diagrami i qarkullimit (shih faqen 34)

- ① Dalja e spërkatëses
- ② Dalja e vaskës



Përdorimi (shih faqen 35)



Mirëmbajtja (shih faqen 36)

10417000 / 17417XXX : Pajisjet në shërbim të sigurisë duhen kontrolluar rregullisht në bazë të normave DIN EN 1717 konform normave nacionale dhe regjionale (DIN 1988 një herë në vit).



Pastrimi

Për rekomandime mbi pastrimin shikoni broshurën bashkëngjitur.



Pjesë ndërrimi (shih faqen 38)



Shenja e kontrollit (shih faqen 40)

Demtim	Shkaku	Ndihme
Armatura punon rende	- Kartusha me defekt, me kalk	- Kembeni kartushen
Armatura pikon	- Kartusha me defekt, depozitime	- Kembeni kartushen
Kalibruesi nuk funksionon	- Dekompozimet	- Pastroni ndërruesin e pozicionit / Vajosni unazat O
	- Presion shumë i ulët i ujit	- Rrisni presionin e ujit
	- Kalibruesi me defekt	- kembeni kalibruesi
Temperaturë e ulët e ujit të ngrohtë, nuk ka ujë të ftohtë. Ngrohësi elektrik i ujit ndizet kur zgjidhet uji i ftohtë.	- Kufiri i ujit të ngrohtë është regjistruar gabim	- Regjistroni kufirin e ujit të ngrohtë
	- Rrjedhje e kryqëzuar.	- Kembeni kartushen



Montimi shih faqen 31



وصف الرمز

هام! لا تستخدم السليكون الذي يحتوي على أحماض!



الضبط (راجع صفحة 33)

لضبط محدد الماء الساخن في الخلاطات ذات المقبض الواحد، يرجى الرجوع إلى صفحة 33. ولا ينصح إجراء أي ضبط عند استخدام سخان مياه ذي تدفق مستمر.



أبعاد (راجع صفحة 34)



رسم للصراف (راجع صفحة 34)



- ① صرف الرشاش
- ② صرف البانيو

التشغيل (راجع صفحة 35)



الصيانة (راجع صفحة 36)



17417XXX / 10417000 : يجب اختبار وظائف تجهيزات الأمان طبقاً للوائح DIN EN 1717 وبشكل دوري وذلك بالتوافق مع القواعد المحلية والجهوية السائدة DIN 1988 وبشكل سنوي.

التنظيف



للاطلاع على النصائح الخاصة بالتنظيف انظر الكتيب المرفق.

قطع الغيار (راجع صفحة 38)



شهادة اختبار (راجع صفحة 40)



تنبيهات الأمان



⚠ يجب إرتداء قفازات لليد أثناء التركيب لتجنب حدوث أضرار الإنحشار أو الجروح.

⚠ لا يجب استخدام نظام الدش إلا في أغراض الاستحمام والأغراض الصحية وأغراض تنظيف الجسم.

⚠ يجب أن يكون تيار الماء الساخن والماء البارد متعادلين في الضغط.

تعليمات التركيب

• قبل القيام بعملية التركيب، يجب فحص المنتج للتأكد من خلوه من أية تلفيات ناتجة عن النقل. بعد القيام بعملية التركيب، لن يتم الاعتراف بوجود أية تلفيات سطحية أو تلفيات ناتجة عن عملية النقل.

• يجب تركيب الوصلة واستخدامها واختبارها وفقاً للمعايير المعمول بها.

المواصفات الفنية

- ضغط التشغيل: الحد الأقصى 1 ميجاباسكال
- ضغط التشغيل الموصى به: 0,1 - 0,5 ميجاباسكال
- ضغط الاختيار: 1,6 ميجاباسكال
- (1 ميجاباسكال = 10 بار = 147 PSI)
- درجة حرارة الماء الساخن: الحد الأقصى 80°C
- درجة الحرارة الموصى بها للماء الساخن: 65°C
- تقييم حراري: الحد الأقصى 70°C / 4 الدقيقة

17417XXX / 10417000 . خاصية عدم التدفق العكسي

المنتج مخصص فقط لماء الشرب!

يمكن استخدام خلاطات هانزجرهوي مع سخانات تدفق الماء ذات التحكم الهيدروليكي و الحراري، مع ضغط تدفق لا يقل عن 0,15 ميجاباسكال.

العطل	السبب	العلاج والإصلاح
الخلاط فقيل الحركة	- الخرطوشة تالفة، تراكم عليها الجير	- قم بتغيير الخرطوشة
تساقط قطرات مياه من الخلاط	- الخرطوشة تالفة، متراكم عليها الترسبات	- قم بتغيير الخرطوشة
المحول لا يعمل	- الرواسب	- تنظيف الخلاط وتنشيم الحلقة الدائرية.
	- ضغط الماء منخفض للغاية	- ارفع ضغط الماء
	- المحول تالف	- قم بتغيير المحول
	- محدد الماء الساخن مضبوط بشكل خاطيء	- قم بضبط محدد الماء الساخن
	- اندفاع متعاكس للمياه	- قم بتغيير الخرطوشة



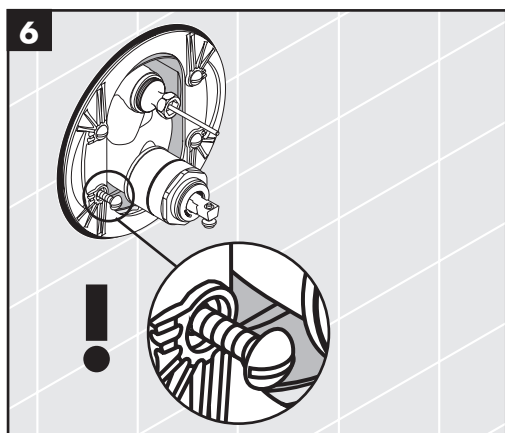
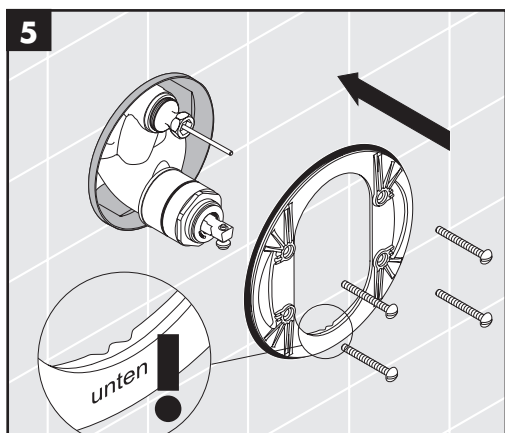
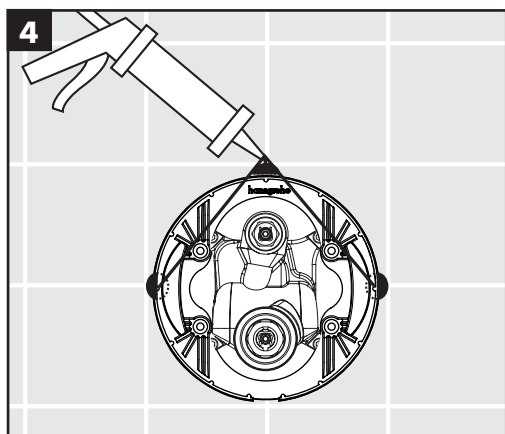
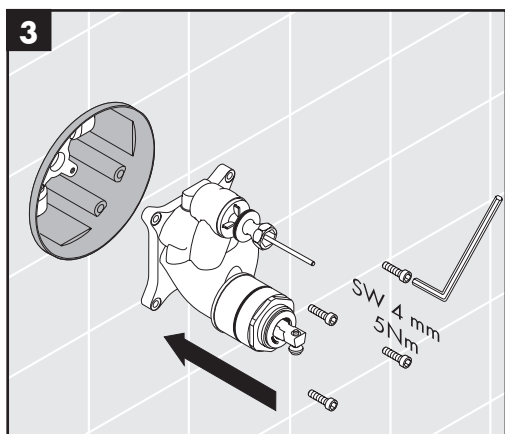
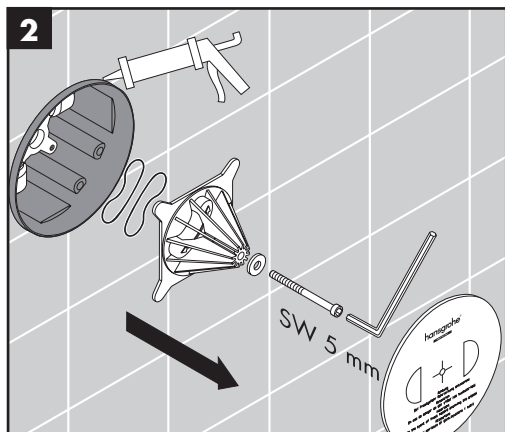
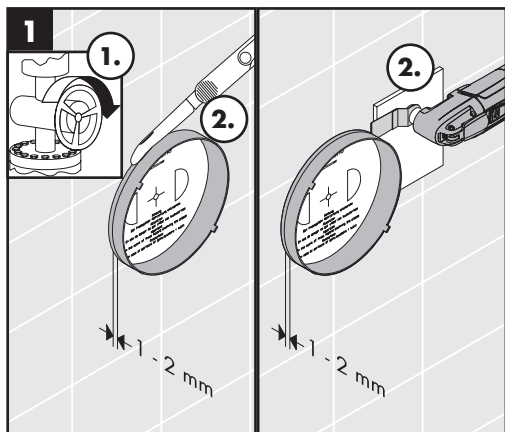

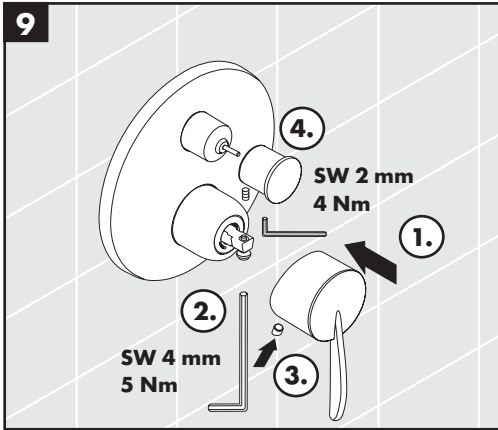
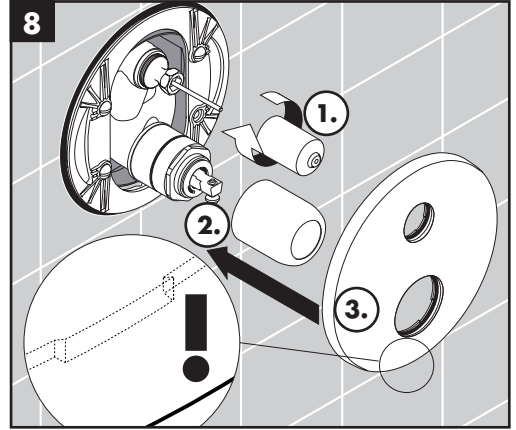
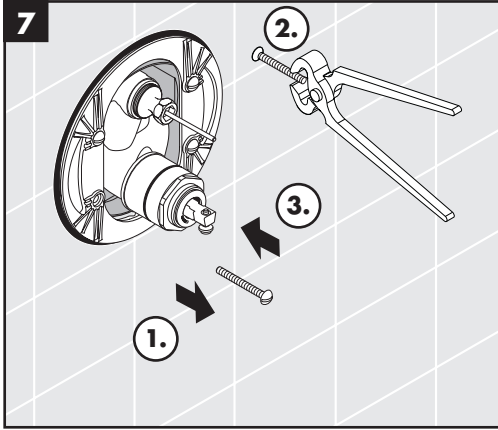

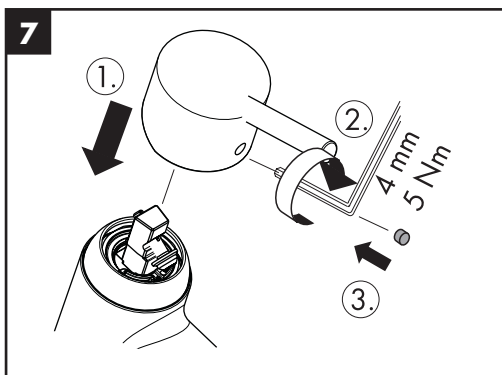
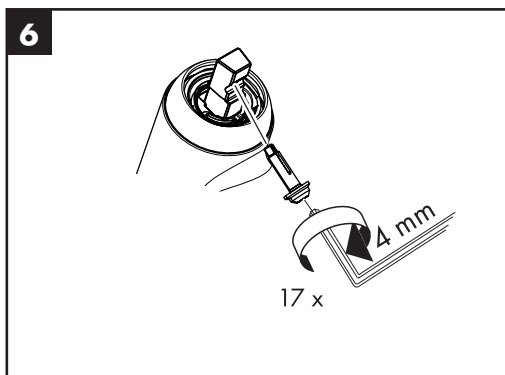
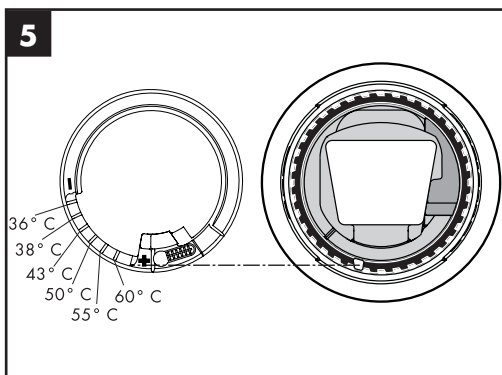
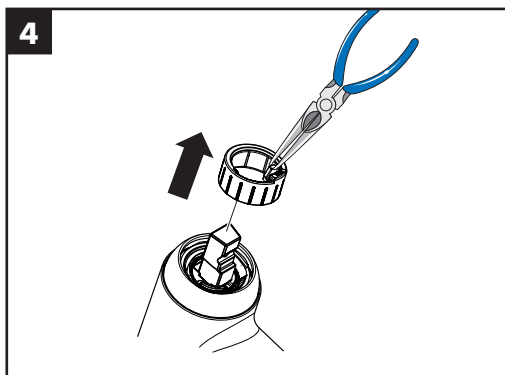
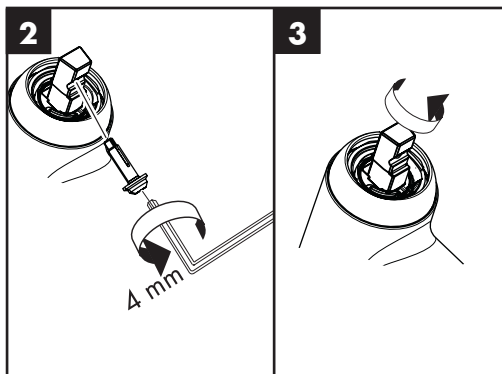
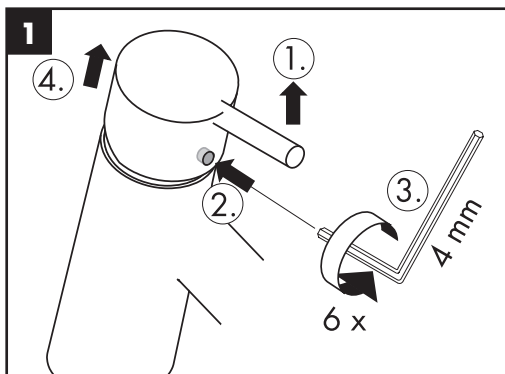



Starck

10415000 /
10415003 /
10417000

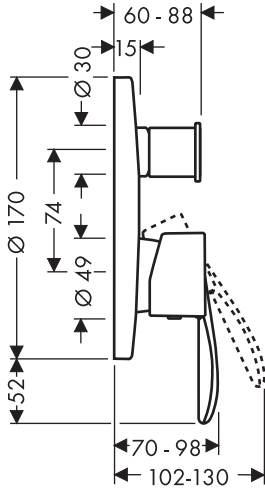

Carlton

17415XXX /
17417XXX

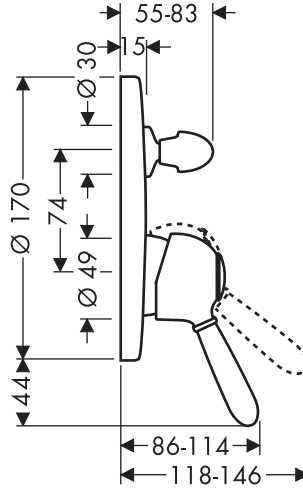

Starck 10415000 / 10415003 / 10417000

Carlton 17415XXX / 17417XXX

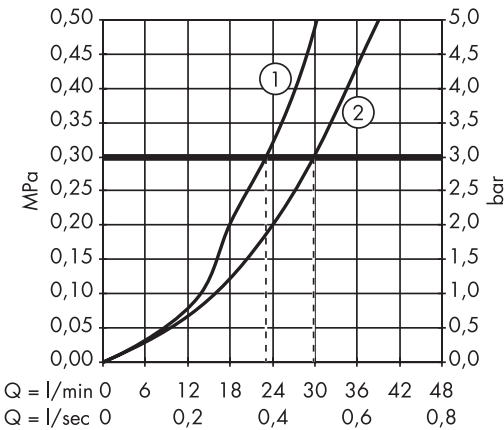

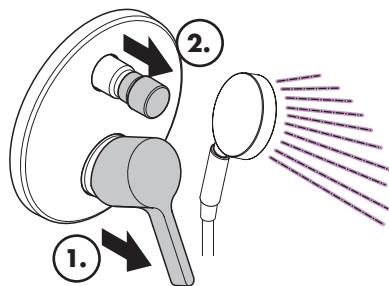
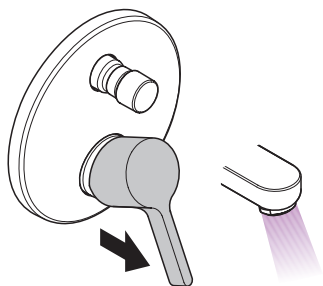

öffnen / ouvert / open / aperto / abierto / open / åbne / abrir / otworzyć / otevřít / otvorit' / 开 / откpыть / nyitás /
avaaminen / öppna / atidaryti / Отваранье / açmak / deschide / ανοικτό / odpreti / avage / atvērt / otvoriti /
årne / отваряне / hare / فتح

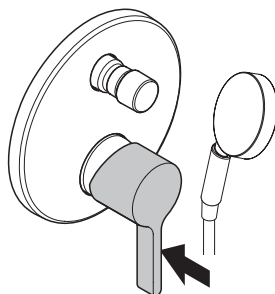
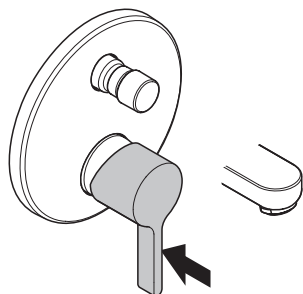

schließen / fermé / close / chiudere / cerrar / sluiten / lukke / fechar / zamknąć / zavřít / uzavrieti' / 关 / закрыть /
bezárás / sulkeminen / stänga / uždaryti / Zatvaranje / kapatmak / închide / κλειστό / zapreti / sulgege / aizvērt /
zatvori / lukke / затваряне / mbylle / إغلاق

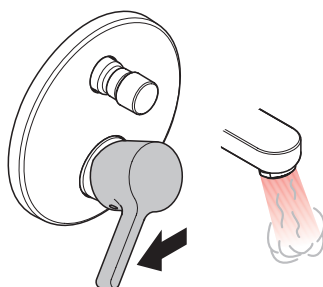

warm / chaud / hot / caldo / caliente / warm / varmt /
quente / ciepła / teplá / teplá / 热 / горячая / meleg /
lämmin / varmi / karštas / Vruća voda / sıcak / cald /
ζεστό / toplo / kuum / karsts / topla / varm / тепло /
i ngrohtë / ساخن

kalt / froid / cold / freddo / frío / koud / koldt / fria /
zimna / studená / studená / 冷 / холодная / hideg /
kylmä / kallt / šaltas / Hladno / soğuk / rece / κρύο /
mrzlo / külm / auksts / hladno / kaldt / студено / i ftohtë /
بارد

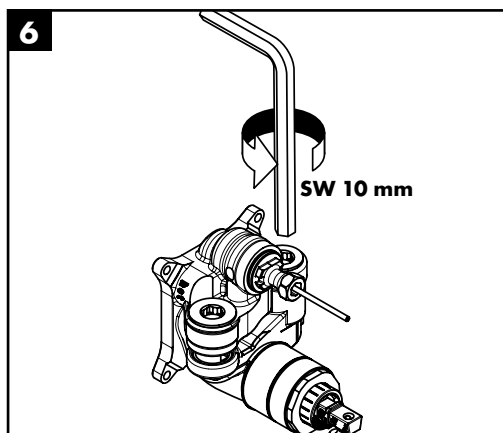
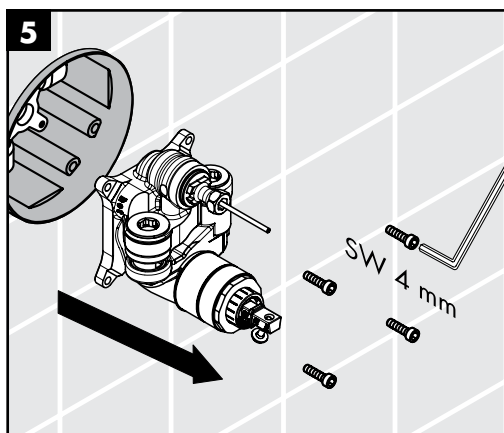
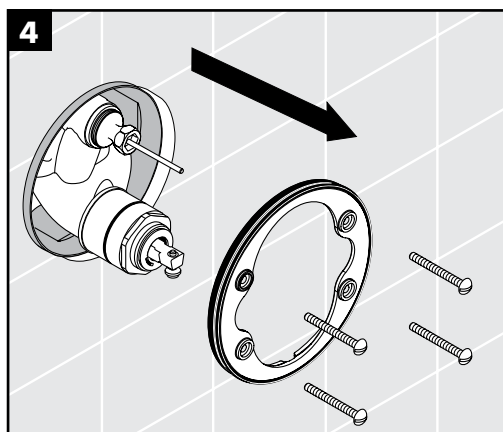
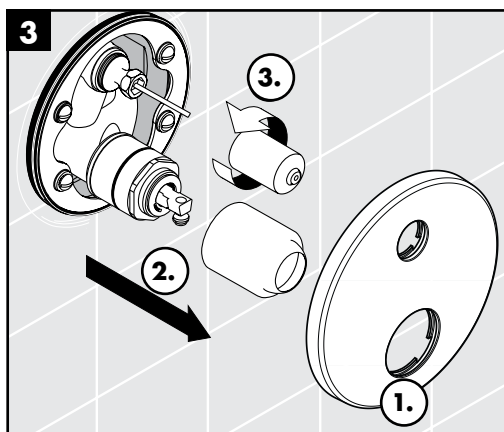
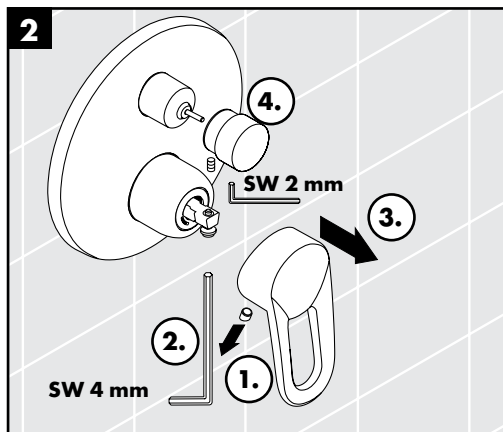
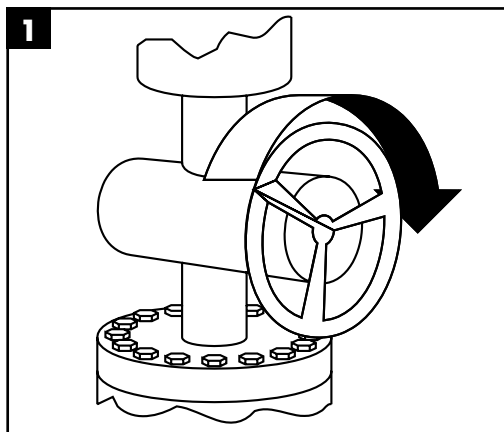

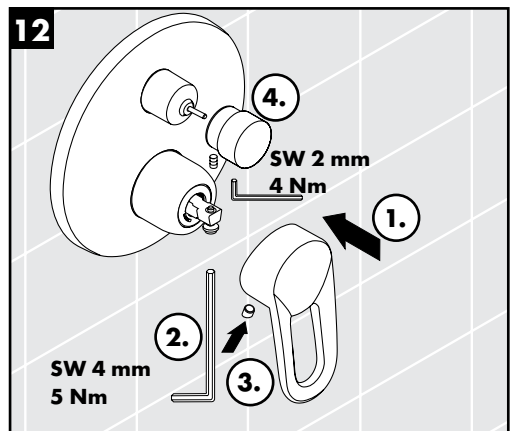
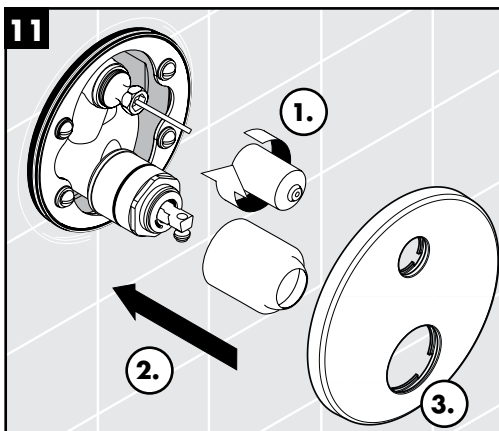
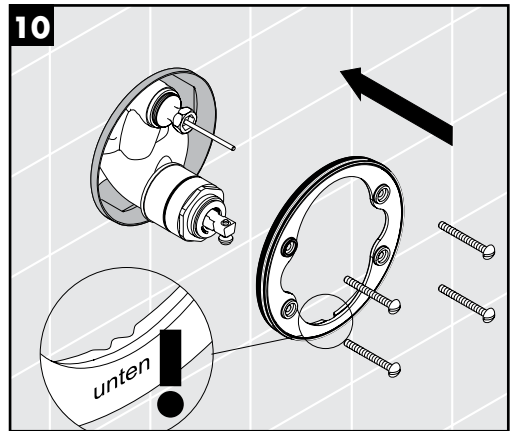
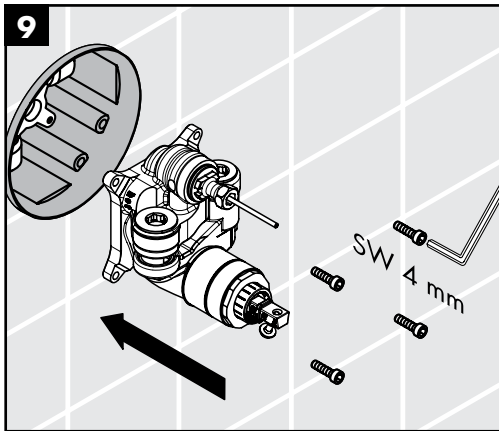
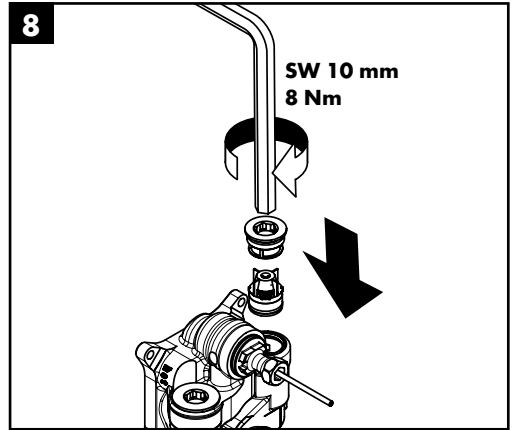
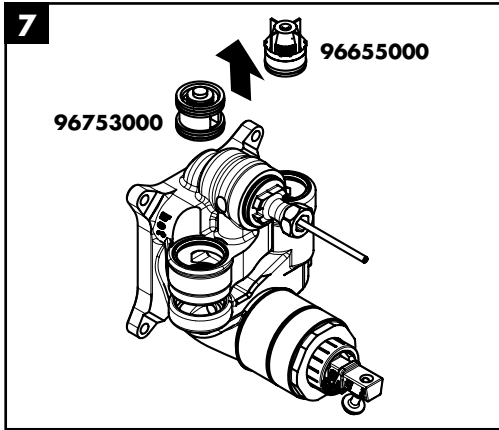

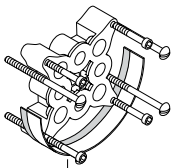
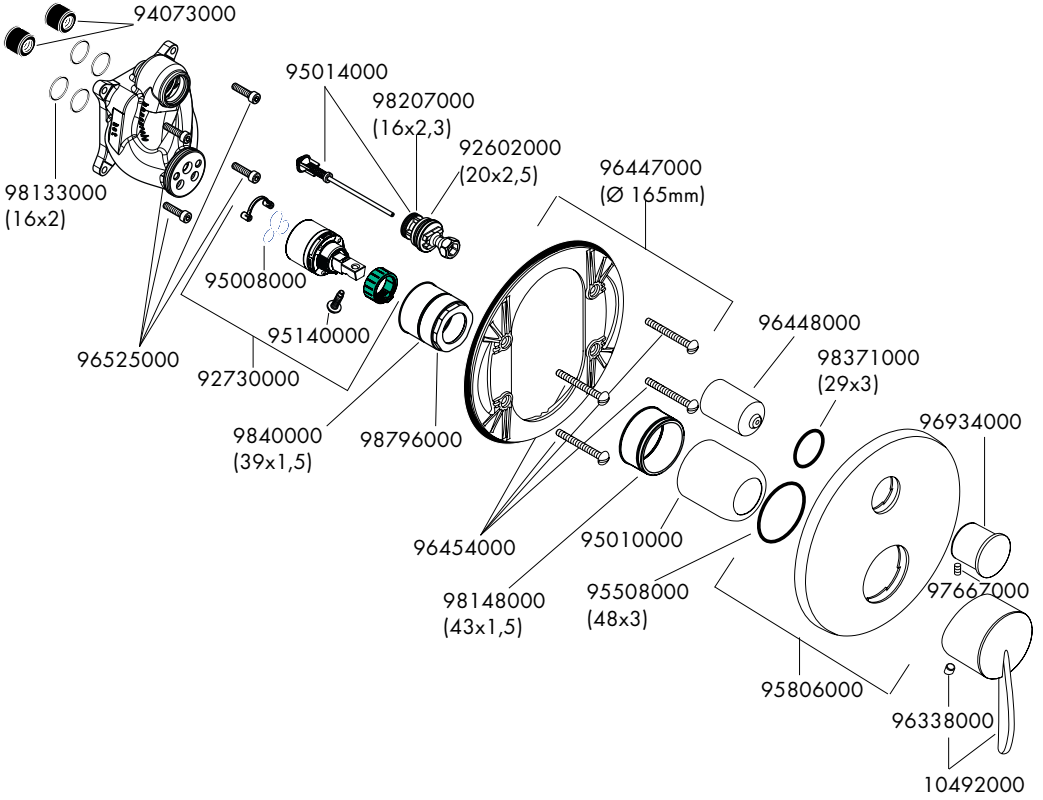

13595000
(25 mm)

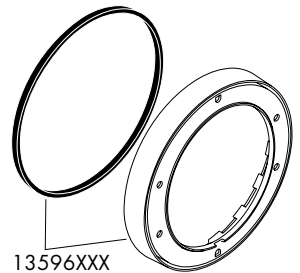
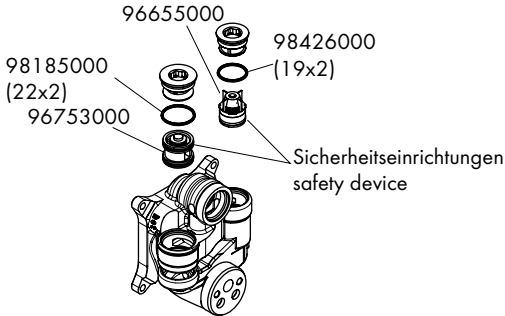

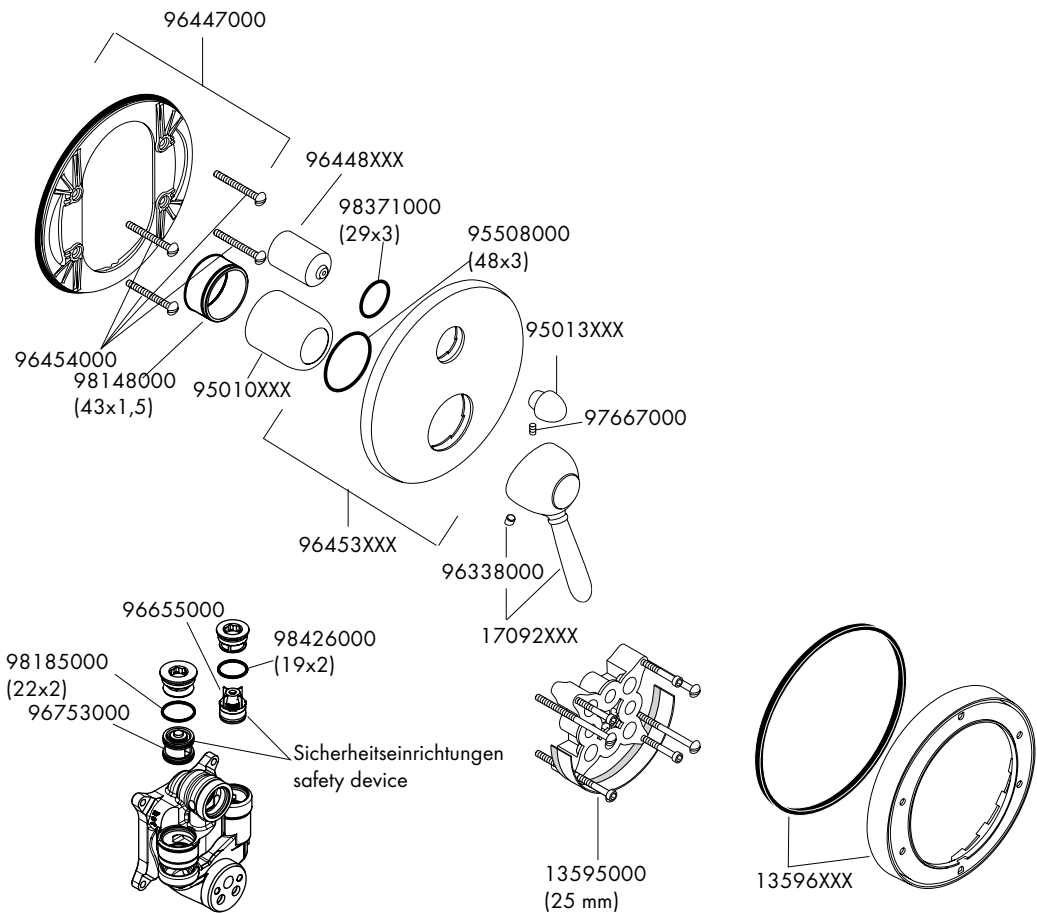



XXX = Farbcodierung // Couleurs // Colors // Trattamento // Acabados // Kleuren // Overflade // Acabamentos // kody wykończenia powierzchni // kód povrchové úpravy // kód povrchovej úpravy // 颜色代码 // Код цвета поверхности // Színkódok // Värikoodi // Färgkodning // Spalva // Boje // Renkler // cod de culori // Χρώματα // الألوان // Barve // Värivkood // Krāsas // Označe boja // Fargekode // Цветово кодиране // Kodimi i ngjyrave

000 = chrom // chromé // chrome plated // cromato // cromado // verchromd // Krom // cromado // chróm // 镀铬 // хром // króm // kromi // krom // crom // Επιχρωμιωμένο // كروم // kroom // hroma // hrom // хром

090 = chrom/gold-optik // chromé/or l'optique // chrome plated/gold plated // cromo/dorado ottica // cromo/oro óptica // chroom/verguld-look // Krom/guld optic // cromado/ouro ótica // chrom/złoty szlachetna // chrom/zlato ocel // chróm/zlato ocel // 镀铬/黑色 // хром/глянцевое золото // króm/arany-hatású // kromi/kultaoptikka // krom/guld-optik // chrominé (aukso optika) // optika krom/zlato // krom/altn-optik // crom/auriu optic // Επιχρωμιωμένο/οπτική χρυσού // كروم/لون ذهبي // krom/pozlačena // kroom/kuld optik // hroma/zelta // dezen hrom/zlatna // krom/gull-optikk // хром/оптика за zlato // krom/i arte-optike



	P-IX	DVGW	SVGW	ACS	WRAS	NF	KIWA	ETA
10415XXX	PA-IX 9709/ICC		X	X	X		X	 1.42/18751
10417XXX	PA-IX 18097/IDC	BN0685	X	X		X		
17415XXX	PA-IX 9709/ICC		X	X	X		X	 1.42/18751
17417XXX		BN0685	X	X		X		

Starck
10415XXX
Carlton
17415XXX

Starck
10417XXX

