

AXOR®

hansgrohe

DE	Gebrauchsanleitung / Montageanleitung	2
FR	Mode d'emploi / Instructions de montage	2
EN	Instructions for use / assembly instructions	3
IT	Istruzioni per l'uso / Istruzioni per Installazione	3
ES	Modo de empleo / Instrucciones de montaje	4
NL	Gebruiksaanwijzing / Handleiding	4
DK	Brugsanvisning / Monteringsvejledning	5
PT	Instruções para uso / Manual de Instalação	5
PL	Instrukcja obsługi / Instrukcja montażu	6
CS	Návod k použití / Montážní návod	6
SK	Návod na použitie / Montážny návod	7
ZH	用户手册 / 组装说明	7
RU	Руководство пользователя / Инструкция по монтажу	8
HU	Használati útmutató / Szerelési útmutató	8
FI	Käyttöohje / Asennusohje	9
SV	Bruksanvisning / Monteringsanvisning	9
LT	Vartotojo instrukcija / Montavimo instrukcijos	10
HR	Upute za uporabu / Uputstva za instalaciju	10
TR	Kullanım kılavuzu / Montaj kılavuzu	11
RO	Manual de utilizare / Instrucțiuni de montare	11
EL	Οδηγίες χρήσης / Οδηγία συναρμολόγησης	12
SL	Navodilo za uporabo / Navodila za montažo	12
ET	Kasutusjuhend / Paigaldusjuhend	13
LV	Lietošanas pamācība / Montāžas instrukcija	13
SR	Uputstvo za upotrebu / Uputstvo za montažu	14
NO	Bruksanvisning / Montasjeveiledning	14
BG	Инструкция за употреба / Ръководство за монтаж	15
SQ	Udhëzuesi i përdorimit / Udhëzime rreth montimit	15
AR	دليل الاستخدام / تعليمات التجميع	16

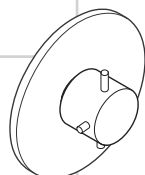

Starck

10970000

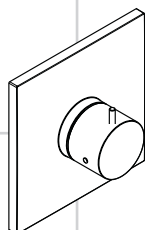

Starck X

10974000

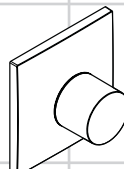

Massaud

18770000

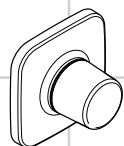

Bouroullec

19971000



Steel

35970800



Sicherheitshinweise

- Bei der Montage müssen zur Vermeidung von Quetsch- und Schnittverletzungen Handschuhe getragen werden.

Montagehinweise

- Die Armatur muss nach den gültigen Normen montiert, gespült und geprüft werden!
- Vor der Montage muss das Produkt auf Transportschäden untersucht werden. Nach dem Einbau werden keine Transport- oder Oberflächenschäden anerkannt.

Consignes de sécurité

- Lors du montage, porter des gants de protection pour éviter toute blessure par écrasement ou coupure.

Instructions pour le montage

- La robinetterie doit être installée, rincée et contrôlée conformément aux normes valables!
- Avant son montage, s'assurer que le produit n'a subi aucun dommage pendant le transport. Après le montage, tout dommage de transport ou de surface ne pourra pas être reconnu.

Symbolerklärung



Kein essigsäurehaltiges Silikon verwenden!



Maße (siehe Seite 19)



Serviceteile (siehe Seite 20)

Description du symbole



Ne pas utiliser de silicone contenant de l'acide acétique!



Dimensions (voir page 19)



Pièces détachées (voir pages 20)

Prüfzeichen (siehe Seite 24)



Reinigung

siehe beiliegende Broschüre.

Classification acoustique et débit (voir page 24)



Nettoyage

voir la brochure ci-jointe.





Safety Notes

- ⚠ Gloves should be worn during installation to prevent crushing and cutting injuries.

Installation Instructions

- The fitting must be installed, flushed and tested after the valid norms!
- Prior to installation, inspect the product for transport damages. After it has been installed, no transport or surface damage will be honoured.

Symbol description



Do not use silicone containing acetic acid!



Dimensions (see page 19)



Spare parts (see page 20)

Indicazioni sulla sicurezza

- ⚠ Durante il montaggio, per evitare ferite da schiacciamento e da taglio bisogna indossare guanti protettivi.

Istruzioni per il montaggio

- La rubinetteria deve essere installata, pulita e testata secondo le istruzioni riportate!
- Prima del montaggio è necessario controllare che non ci siano stati danni durante il trasporto. Una volta eseguito il montaggio, non verranno riconosciuti eventuali danni di trasporto o delle superfici.

Descrizione simbolo



Non utilizzare silicone contenente acido acetico!



Ingombri (vedi pagg. 19)



Parti di ricambio (vedi pagg. 20)

Test certificate (see page 24)

Segno di verifica (vedi pagg. 24)



Cleaning

see enclosed brochure.



Pulitura

vedi il prospetto accluso.

Assembly
see page 17



Montaggio
vedi pagg. 17



Indicaciones de seguridad

- ⚠ Durante el montaje deben utilizarse guantes para evitar heridas por aplastamiento o corte.

Indicaciones para el montaje

- El grifo tiene que ser instalado, probado y testado, según las normas en vigor.
- Antes del montaje se debe examinarse el producto contra daños de transporte. Después de la instalación so se reconoce ningún daño de transporte o de superficie.

Descripción de símbolos



No utilizar silicona que contiene ácido acético!



Dimensiones (ver página 19)



Repuestos (ver página 20)

Veiligheidsinstructies

- ⚠ Bij de montage moeten ter voorkoming van knel- en snijwonden handschoenen worden gedragen.

Montage-instructies

- Leidingen doorspoelen volgens Norm. De mengkraan vervolgens monteren en controleren!
- Vóór de montage moet het product gecontroleerd worden op transportschade. Na de inbouw wordt geen transport- of oppervlakteschade meer aanvaard.

Symbolbeschrijving



Gebruik geen zuurhoudende silicone!



Maten (zie blz. 19)



Service onderdelen (zie blz. 20)

Marca de verificación (ver página 24)



Limpiar

ver el folleto adjunto.

Keurmerk (zie blz. 24)



Reinigen

zie bijgevoegde brochure.





Sikkerhedsanvisninger

- ⚠ Ved monteringen skal der bruges handsker for at undgå kvæstelser og snitsår.

Monteringsanvisninger

- Ifølge gældende regler, skal armeturet monteres, skylles igennem og afprøves.
- Før monteringen skal produktet kontrolleres for transportskader. Efter monteringen godkendes transportskader eller skader på overfladen ikke længere.

Avisos de segurança

- ⚠ Durante a montagem devem ser utilizadas luvas de protecção, de modo a evitar ferimentos resultantes de entalamentos e de cortes.

Avisos de montagem

- A misturadora deve ser instalada, purgada e testada de acordo com as normas em vigor!
- Antes da montagem deve-se controlar o produto relativamente a danos de transporte. Após a montagem não são aceites quaisquer danos de transporte ou de superfície.

Symbolbeskrivelse



Der må ikke benyttes eddikesyreholdig silikone!



Målene (se s. 19)



Reservedele (se s. 20)

Descrição do símbolo



Não utilizar silicone que contenha ácido acético!



Medidas (ver página 19)



Peças de substituição (ver página 20)

Godkendelse (se s. 24)



Rengøring

se venligst den vedlagte brochure.

Marca de controlo (ver página 24)



Limpeza

consultar a seguinte brochura.

Montering
se s. 17



Montagem
ver página 17



Wskazówki bezpieczeństwa

- ⚠ Aby uniknąć zranień, takich jak zgniecenia czy przecięcia, podczas montażu należy nosić rękawice.

Wskazówki montażowe

- Armatura musi być zamontowana, przepłukana i wypróbowana według obowiązujących norm!
- Przed montażem należy skontrolować produkt pod kątem szkód transportowych. Po montażu nie widać żadnych szkód transportowych ani szkód na powierzchni.

Bezpečnostní pokyny

- ⚠ Pro zabránění řezným zraněním a pohmožděním je nutné při montáži nosit rukavice.

Pokyny k montáži

- Armatura se musí montovat, proplachovat a testovat podle platných norem!
- Před montáží je třeba produkt zkontrolovat, zda nebyl při transportu poškozen. Po zabudování nebudou uznány žádné škody způsobené transportem nebo poškození povrchu.

Opis symbolu



Nie stosować silikonów zawierających kwas octowy!



Wymiary (patrz strona 19)



Części serwisowe (patrz strona 20)

Popis symbolů



Nepoužívat silikon s obsahem kyseliny octové!



Rozměry (viz strana 19)



Servisní díly (viz strana 20)

Znak jakości (patrz strona 24)

Zkušební značka (viz strana 24)



Czyszczenie

patrz dołączona broszura.



Čištění

viz přiložená brožura.





Bezpečnostné pokyny

-  Pri montáži musíte nosiť rukavice, aby ste predišli pomliaždeninám a rezným poraneniam.

Pokyny pre montáž

- Batéria sa musí montovať, preplachovať a testovať podľa platných noriem!
- Pred montážou musíte produkt skontrolovať, či nebol počas transportu poškodený. Po zabudovaní nebudú uznané žiadne škody spôsobené transportom alebo poškodenia povrchu.

Popis symbolov



Nepoužívať silikón s obsahom kyseliny octovej!



Rozmery (viď strana 19)



Servisné diely (viď strana 20)

安全技巧

-  装配时为避免挤压和切割受伤，必须戴上手套。

安装提示

- 必须按照现行的规定安装，冲洗和测试产品！
- 安装前必须检查产品是否受到运输损害。安装后将不认可运输损害或表面损伤。

符号说明



请勿使用含有乙酸的硅！



大小 (参见第 19 页)



备用零件 (参见第 20 页)

Osvedčenie o skúške (viď strana 24)

检验标记 (参见第 24 页)



Čistenie

nájdete v priloženej brožúre.



清洗

附有小手册

Montáž
viď strana 17



安装
参见第 17 页



Указания по технике безопасности

-  Во время монтажа следует надеть перчатки во избежание прищемления и порезов.

Указания по монтажу

- Смеситель должен быть смонтирован по действующим нормам и в соответствии с настоящей инструкцией, проверен на герметичность и безупречность работы
- Перед монтажом следует проверить изделие на предмет повреждений при перевозке. После монтажа претензии о возмещении ущерба за повреждения при перевозке или повреждения поверхностей не принимаются.

Описание символов



Не применяйте силикон, содержащий уксусную кислоту.



Размеры (см. стр. 19)



Комплект (см. стр. 20)

Biztonsági utasítások

-  A szerelésnél a zúzódások és vágási sérülések elkerülése érdekében kesztyűt kell viselni.

Szerelési utasítások

- A csaptelepet az érvényben lévő előírásoknak megfelelően kell felszerelni, átöblíteni és ellenőrizni!
- A szerelés előtt ellenőrizni kell, hogy a terméknek nincs-e szállítási sérülése. Beépítés után a szállítási- vagy felületi sérüléseket nem ismerik el.

Szimbólumok leírása



Ne használjon ecetsavtartalmú szilikont!



Méretet (lásd a 19. oldalon)



Tartozékok (lásd a 20. oldalon)

Знак технического контроля
(см. стр. 24)



Очистка

см прилагаемая брошюра

Vizsgajel (lásd a 24. oldalon)



Tisztítás

lásd a mellékelt brosrútát.





Turvallisuusohjeet

- Asennuksessa on käytettävä käsineitä puristumien ja viiltojen aiheuttamien tapaturmien estämiseksi.

Asennusohjeet

- Kaluste on asennettava, huuhdeltava ja tarkastettava voimassa olevien määräysten mukaisesti!
- Ennen asennusta on tarkastettava tuotteen mahdolliset kuljetusvahingot. Asennuksen jälkeen kuljetus- ja pintavaurioita ei hyväksytä.

Säkerhetsanvisningar

- Handskar ska bäras under monteringsarbetet så att man kan undvika kläm- och skärskadorgen werden.

Monteringsanvisningar

- Blandaren måste installeras, genomspolas och testas enligt gällande föreskrifter.
- Det måste undersökas om produkten har transportskador innan den monteras. Efter monteringen accepteras inga transport- eller ytskiktsskador.

Merkin kuvaus



Älä käytä etikahappopitoista silikonia!



Mitat (katso sivu 19)



Varaosat (katso sivu 20)

Symbolförklaring



Använd inte silikon som innehåller ättiksyra!



Måtten (se sidan 19)



Reservdelar (se sidan 20)

Koestusmerkki (katso sivu 24)

Testsigill (se sidan 24)



Puhdistus

katso oheinen esite



Rengöring

se den medföljande broschyren

Asennus
katso sivu 17



Montering
se sidan 17



Saugumo technikos nurodymai

-  Apsaugai nuo užspaudimo ir įsijovavimo montavimo metu dėvėkite pirštines.

Montavimo instrukcija

- Maišytuvas privalo būti montuojamas, išleidžiamas ir patikrinamas pagal galiojančias normas!
- Prieš montuojant būtina patikrinti, ar gaminyje nebuvo pažeistas transportavimo metu. Sumontavus pretenzijos dėl transportavimo ir paviršiaus pažeidimų nepriimamos.

Sigurnosne upute

-  Prilikom montaže se radi sprječavanja prignječnja i posjekotina moraju nositi rukavice.

Upute za montažu

- Cijevi moraju biti postavljene, isprane i testirane prema važećim normama!
- Prije montaže mora se provjeriti je li proizvod oštećen prilikom transporta. Nakon ugradnje se ne priznaju nikakve reklamacije koje se odnose na površinska i transportna oštećenja.

Simbolio aprašymas



Nenaudokite silikono, kurio sudėtyje yra acto rūgšties!



Išmatavimai (žr. psl. 19)



Atsarginės dalys (žr. psl. 20)

Opis simbola



Nemojte koristiti silikon koji sadrži octenu kiselinu!



Mjere (pogledaj stranicu 19)



Rezervni djelovi (pogledaj stranicu 20)

Bandymo pažyma (žr. psl. 24)



Valymas

žr. pridedamoje brošiūroje.

Oznaka testiranja (pogledaj stranicu 24)



Čišćenje

se u priloženoj brošiuri.

Montavimas
žr. psl. 17



Sastavljanje
pogledaj stranicu 17



! Güvenlik uyarıları

- ! Montaj esnasında ezilme ve kesilme gibi yaralanmaları önlemek için eldiven kullanılmalıdır.

Montaj açıklamaları

- Batarya geçerli normlara göre monte edilmeli, yıkanmalı ve kontrol edilmelidir!
- Montaj işleminden önce ürün nakliye hasarları yönünden kontrol edilmelidir. Montaj işleminden sonra nakliye veya yüzey hasarları için sorumluluk üstlenilmemektedir.

Simge açıklaması



Asetik asit içeren silikon kullanmayın!



Ölçüleri (Bakınız sayfa 19)



Yedek Parçalar (Bakınız sayfa 20)

! Instrucțiuni de siguranță

- ! La montare utilizați mănuși pentru evitarea contuziunilor și tăierii mâinilor.

Instrucțiuni de montare

- Bateria trebuie montată, clătită și verificată conform normelor în vigoare.
- Înainte de instalare verificați, dacă produsul prezintă deteriorări de transport. După instalare garanția nu acoperă deteriorările de transport și cele de suprafață.

Descrierea simbolurilor



Nu utilizați silicon cu conținut de acid acetic!



Dimensiuni (vezi pag. 19)



Piese de schimb (vezi pag. 20)

Kontrol işareti (Bakınız sayfa 24)



Temizleme

birlikte verilen broşür

Certificat de testare (vezi pag. 24)



Curățare

vezi broșura alăturată.

Montajı
Bakınız sayfa 17



Montare
vezi pag. 17



Υποδείξεις ασφαλείας

 Για να αποφύγετε τραυματισμούς κατά τη συναρμολόγηση πρέπει να φοράτε γάντια.

Οδηγίες συναρμολόγησης

- Η κεντρική βάνα πρέπει να τοποθετηθεί, να πλυθεί και να ελεγχθεί με βάση τους ισχύοντες κανόνες υδραυλικής τέχνης!
- Πριν τη συναρμολόγηση πρέπει να εξεταστεί το προϊόν για ζημιές μεταφοράς. Μετά την εγκατάσταση δεν αναγνωρίζονται ζημιές από τη μεταφορά ή επιφανειακές ζημιές.

Varnostna opozorila

 Lors du montage, porter des gants de protection pour éviter toute blessure par écrasement ou coupure.

Navodila za montažo

- Armaturu je potrebno montirati, sprati in testirati v skladu z veljavnimi normami!
- Pred montažo je treba izdelek preveriti glede morebitnih transportnih poškodb. Po vgradnji transportne ali površinske poškodbe ne bodo več priznane.

Περιγραφή συμβόλων



Μην χρησιμοποιείτε σιλικόνη που περιέχει οξικό οξύ!

Διαστάσεις (βλ. σελίδα 19)



Ανταλλακτικά (βλ. σελίδα 20)



Opis simbola



Ne smete uporabiti silikona, ki vsebuje ocetno kislino!

Mere (glejte stran 19)



Rezervni deli (glejte stran 20)



Σήμα ελέγχου (βλ. σελίδα 24)

Καθαρισμός

βλ. συνημμένο φυλλάδιο



Preskusni znak (glejte stran 24)

Čiščenje

glejte priloženi brošuri.



Συναρμολόγηση
βλ. σελίδα 17



Montaža
Glejte stran 17.

**⚠ Ohutusjuhised**

- ⚠ Kandke paigaldamisel muljumis- ja löikevigastuste vältimiseks kindaid.

Paigaldamisjuhised

- Segisti paigaldamine, loputamine ja kontroll peab toimuma vastavalt kehtivatele normidele!
- Enne paigaldamist tuleb toodet kontrollida transpordikahjustuste osas. Pärast paigaldamist ei tunnustata enam transpordi- või pinnakahjustuste kaebuseid.

⚠ Drošības norādes

- ⚠ Montāžas laikā, lai izvairītos no saspiedumiem un iegriezumiem, nepieciešams nēsāt cimdus.

Norādījumi montāžai

- Armatūra jāuzstāda, jāizskalo un jāpārbauda atbilstoši spēkā esošajām normām!
- Pirms montāžas nepieciešams pārbaudīt, vai produktam transportēšanas laikā nav radušies bojājumi. Pēc iebūvēšanas bojājumi, kas radušies transportēšanas laikā, vai virsmas bojājumi netiek atzīti.

Sūmbolite kirjeldus

Ärge kasutage äädikhapet sisaldavat silikooni!



Mõõtude (vt lk 19)



Varuosad (vt lk 20)

Simbolu nozīme

Neizmantojiet silikonu, kas satur etiķskābi!



Izmērus (skat. 19. lpp.)



Rezerves daļas (skat. 20. lpp.)

Kontrollsertifikaat (vt lk 24)

Pārbaudes zīme (skat. 24. lpp.)



Puhastamine

vt kaasaolevast brošūrist.



Tīrīšana

skatiet pievienotajā brošūrā.

**Paigaldamine
vt lk 17**



**Montāža
skat. 17. lpp.**



Sigurnosne napomene

- ⚠ Prilikom montaže se radi sprečavanja prignječenja i posekotina moraju nositi rukavice.

Instrukcije za montažu

- Armatura mora biti postavljena, isprana i testirana prema važećim normama!
- Pre montaže se mora proveriti da li je proizvod oštećen pri transportu. Nakon ugradnje se ne priznaju nikakve reklamacije koje se odnose na površinska i transportna oštećenja.

Opis simbola



Nemojte koristiti silikon koji sadrži sirćetnu kiselinu!



Mere (vidi stranu 19)



Rezervni delovi (vidi stranu 20)

Sikkerhetshenvisninger

- ⚠ Bruk hansker under montasjen for å unngå klem- og kuttskader.

Montagehenvisninger

- Armaturen skal monteres iht. gyldige standarder. De skal spyles og sjekkes!
- Før montasjen skal produktet sjekkes for transportskader. Etter monteringen aksepteres ikke noen transport- eller overflateskader.

Symbolbeskrivelse



Ikke bruk silikon som inneholder eddiksyre!



Mål (se side 19)



Serviceleder (se side 20)

Ispitni znak (vidi stranu 24)

Prøvermerke (se side 24)



Čišćenje

vidi priloženoj brošuri.



Rengjøring

se vedlagt brosjyre.





Указания за безопасност

- ⚠ При монтажа трябва да се носят ръкавици, за да се избегнат наранявания поради притискане или порязване.

Указания за монтаж

- Арматурата трябва да се монтира, промие и провери в съответствие с валидните норми!
- Преди монтажа продуктът трябва да се провери за транспортни щети. След монтажа не се признават транспортни или повърхностни щети.

Udhëzime sigurie

- ⚠ Për të evituar lëndimet e pickimeve ose të prerjeve gjatë procesit të montimit duhet që të vishni doreza.

Udhëzime për montimin

- Armatura duhet montuar, shpërlarë dhe kontrolluar në bazë të normave të vlefshme!
- Përpara montimit duhet që produkti të kontrollohet për dëmtime nga transporti. Pas instalimit nuk do të njihet asnjë dëmtim nga transporti ose dëmtim i sipërfaqes.

Описание на символите



Не използвайте силикон, съдържащ оцетна киселина!



Размери (вижте стр. 19)



Сервизни части (вижте стр. 20)

Përshkrimi i simbolit



Mos përdorni silikon që në përbërje ka acid acetik.



Përmasat (shih faqen 19)



Pjesë ndërrimi (shih faqen 20)

Контролен знак (вижте стр. 24)



Почистване

от приложената брошура.

Shenja e kontrollit (shih faqen 24)



Pastrimi

shikoni broshurën bashkëngjitur.

Монтаж
вижте стр. 17



Montimi
shih faqen 17



⚠️ تنبيهات الأمان

⚠️ يجب ارتداء قفازات لليد أثناء التركيب لتجنب حدوث أضرار الإنحسار أو الجروح.

تعليمات التركيب

- يجب تركيب الوصلة، وغمرها بالماء واختبارها وفقاً للمعايير السارية!
- قبل القيام بعملية التركيب، يجب فحص المنتج للتأكد من خلوه من أية تلفيات ناتجة عن النقل. بعد القيام بعملية التركيب، لن يتم الاعتراف بوجود أية تلفيات سطحية أو تلفيات ناتجة عن عملية النقل.

وصف الرمز

هام! لا تستخدم السليكون الذي يحتوي على أحماض!



أبعاد (راجع صفحة 19) 

قطع الغيار (راجع صفحة 20) 

شهادة اختبار (راجع صفحة 24)

التنظيف



راجع والكتيب المرفق

التركيب
راجع صفحة 17



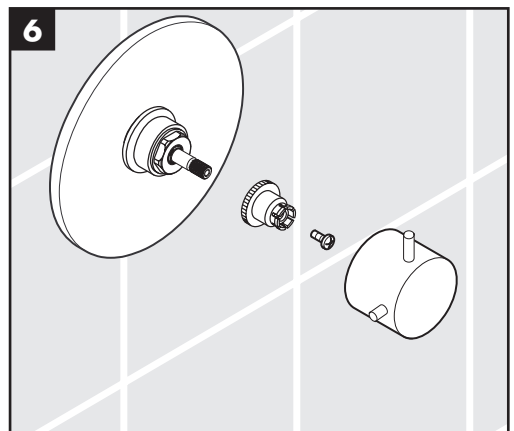
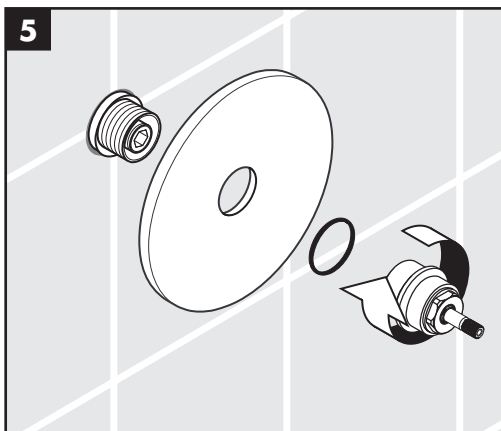
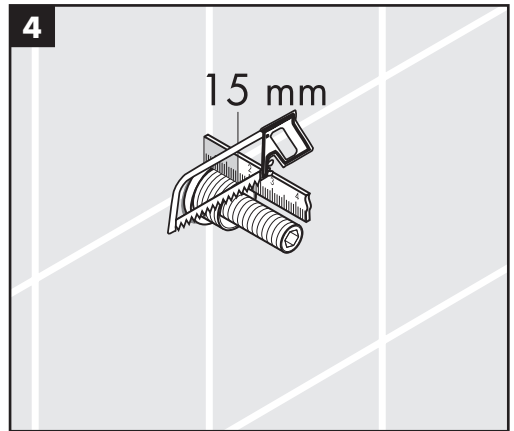
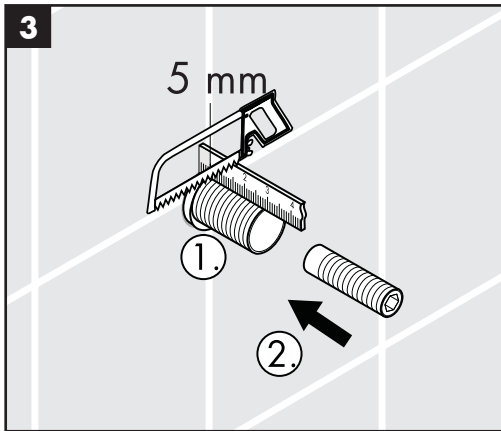
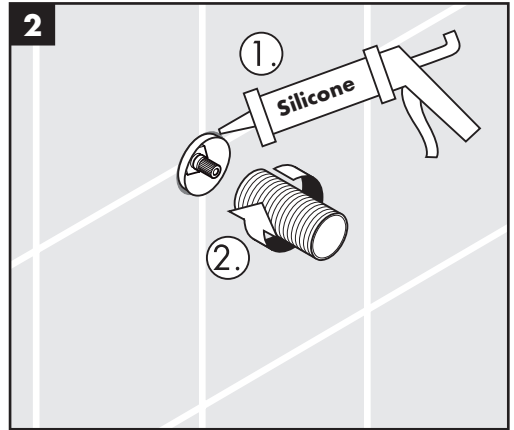
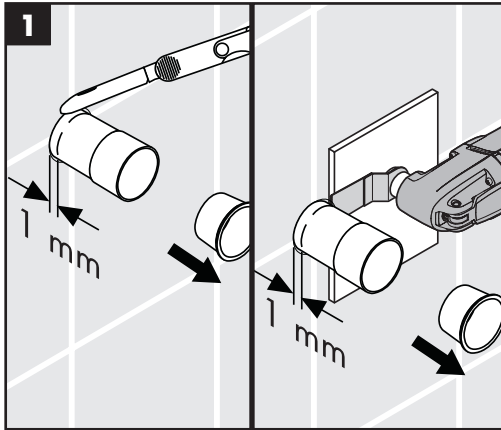

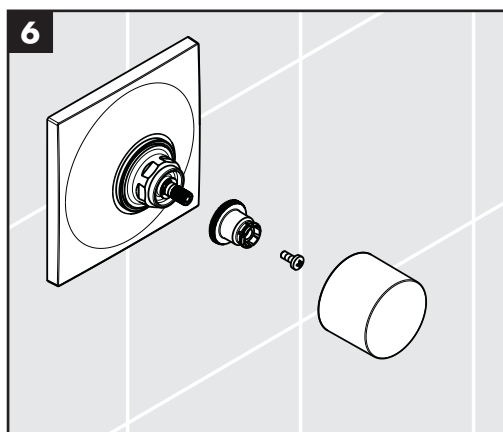
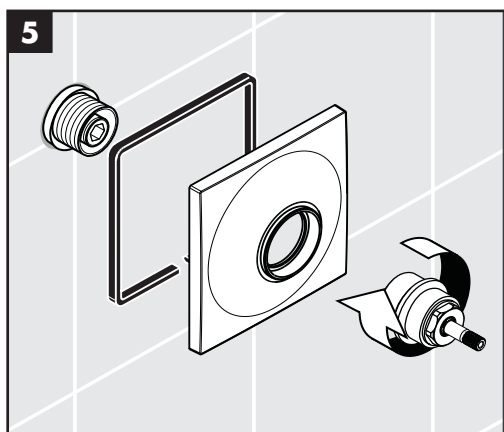
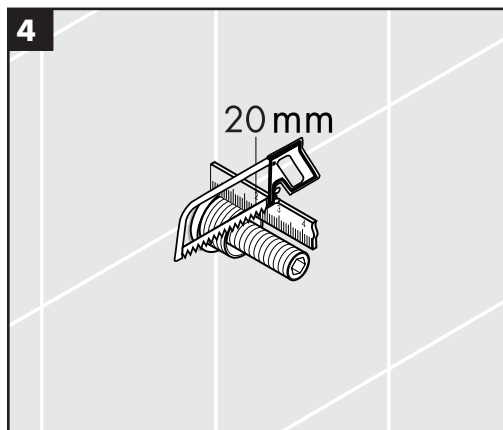
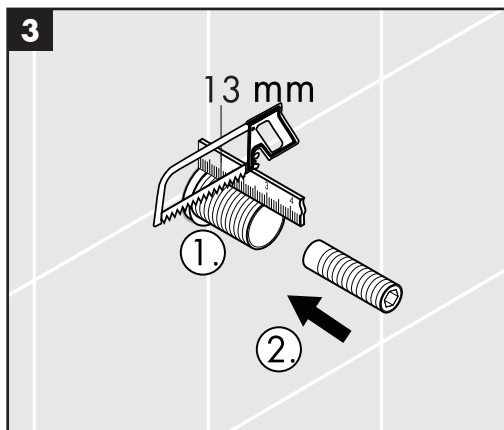
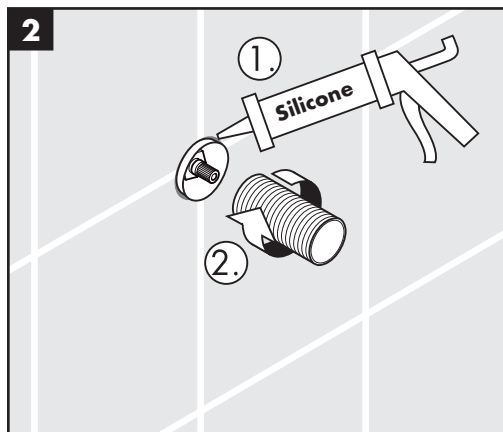
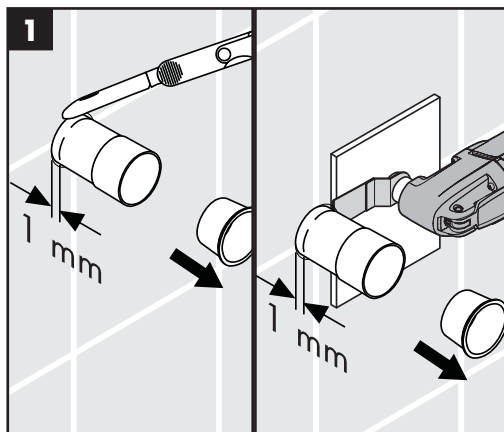



Starck
10970XXX

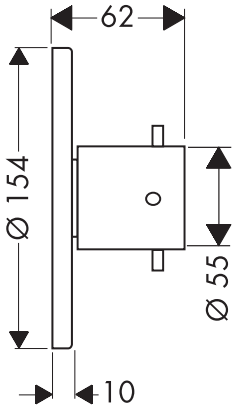

Starck X
10974000

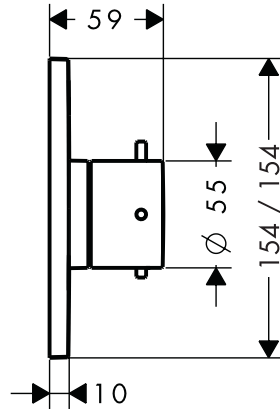

Massaud
18770000

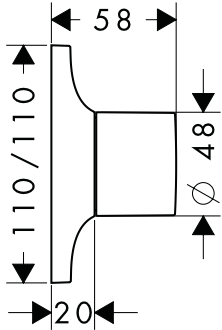

Bouroullec
19971000

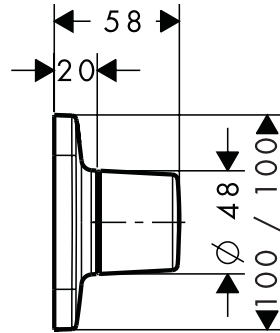

Steel
35970800

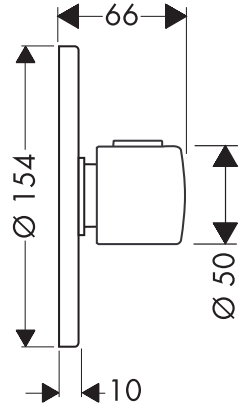



Starck 10970000 / Steel 35970800

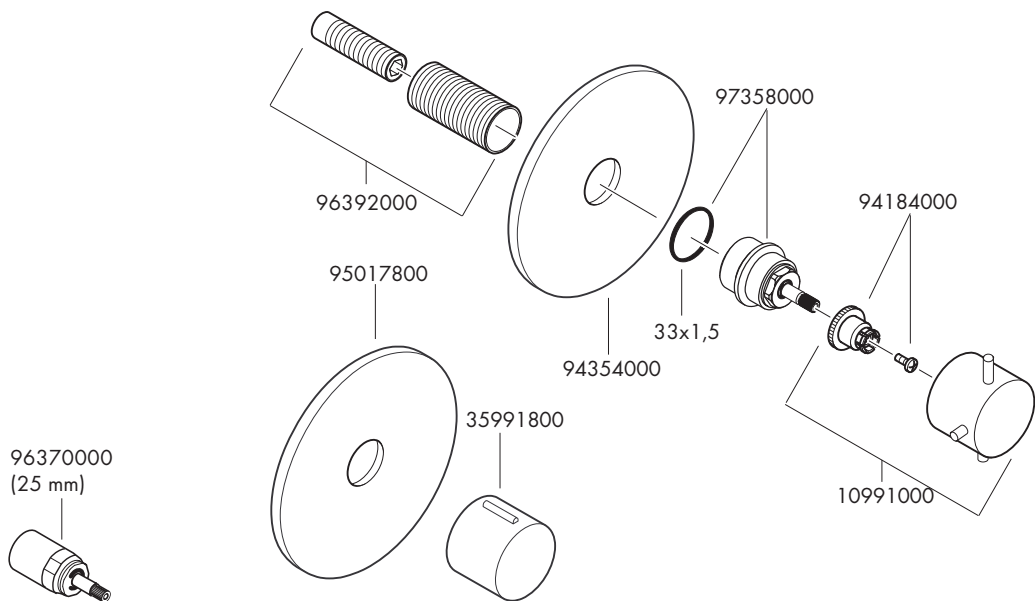

Starck X 10974000

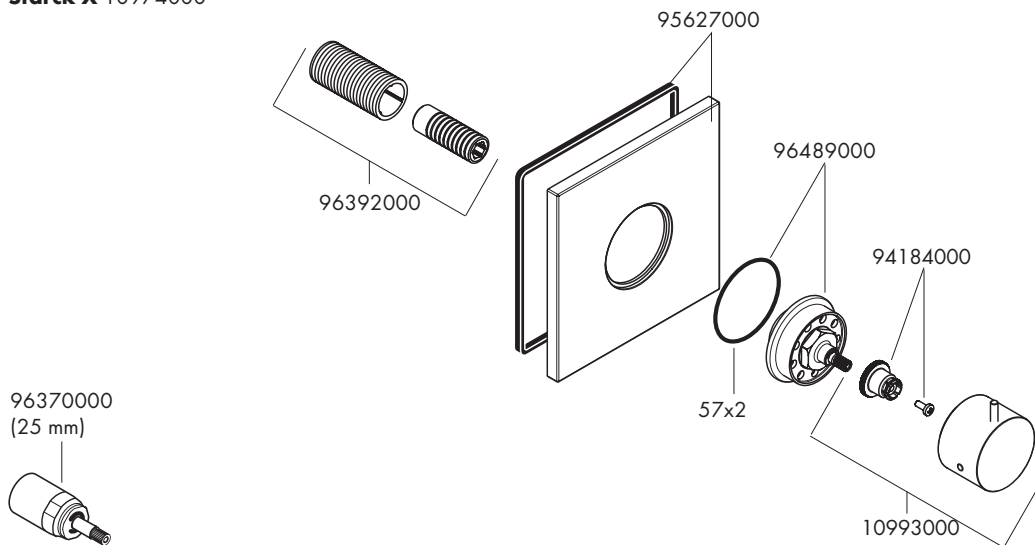



Massaud 18770000

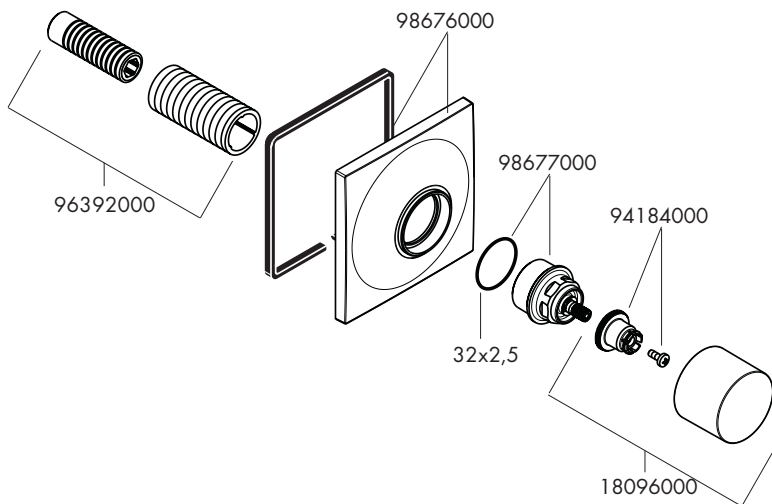

96370000
(25 mm)



Bouroullec 19971000

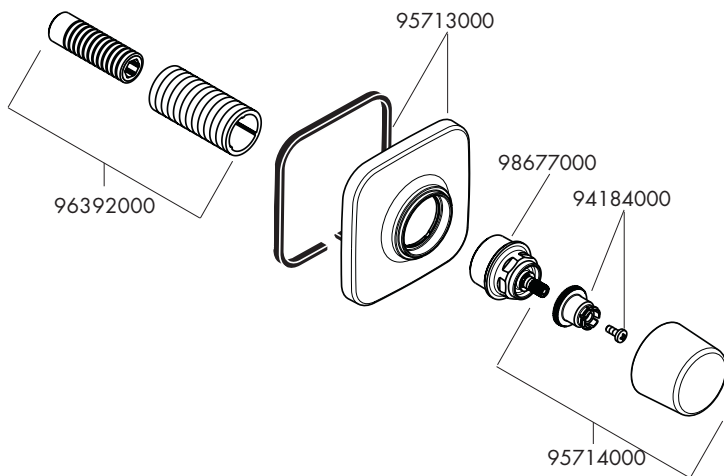

96370000
(25 mm)

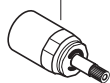





	PA-IX	DVGW	SVGW	ACS	WRAS	MCA	KIWA	NF
10970000			X	X	X			
10974000					X			
18770000			X	X	X			
19971000					X			
35970800			X	X	X			