

# AXOR®

hansgrohe

<b>DE</b>	Gebrauchsanleitung / Montageanleitung	<b>2</b>
<b>FR</b>	Mode d'emploi / Instructions de montage	<b>3</b>
<b>EN</b>	Instructions for use / assembly instructions	<b>4</b>
<b>IT</b>	Istruzioni per l'uso / Istruzioni per Installazione	<b>5</b>
<b>ES</b>	Modo de empleo / Instrucciones de montaje	<b>6</b>
<b>NL</b>	Gebruiksaanwijzing / Handleiding	<b>7</b>
<b>DK</b>	Brugsanvisning / Monteringsvejledning	<b>8</b>
<b>PT</b>	Instruções para uso / Manual de Instalação	<b>9</b>
<b>PL</b>	Instrukcja obsługi / Instrukcja montażu	<b>10</b>
<b>CS</b>	Návod k použití / Montážní návod	<b>11</b>
<b>SK</b>	Návod na použitie / Montážny návod	<b>12</b>
<b>ZH</b>	用户手册 / 组装说明	<b>13</b>
<b>RU</b>	Руководство пользователя / Инструкция по монтажу	<b>14</b>
<b>HU</b>	Használati útmutató / Szerelési útmutató	<b>15</b>
<b>FI</b>	Käyttöohje / Asennusohje	<b>16</b>
<b>SV</b>	Bruksanvisning / Monteringsanvisning	<b>17</b>
<b>LT</b>	Vartotojo instrukcija / Montavimo instrukcijos	<b>18</b>
<b>HR</b>	Upute za uporabu / Uputstva za instalaciju	<b>19</b>
<b>TR</b>	Kullanım kılavuzu / Montaj kılavuzu	<b>20</b>
<b>RO</b>	Manual de utilizare / Instrucțiuni de montare	<b>21</b>
<b>EL</b>	Οδηγίες χρήσης / Οδηγία συναρμολόγησης	<b>22</b>
<b>SL</b>	Navodilo za uporabo / Navodila za montažo	<b>23</b>
<b>ET</b>	Kasutusjuhend / Paigaldusjuhend	<b>24</b>
<b>LV</b>	Lietošanas pamācība / Montāžas instrukcija	<b>25</b>
<b>SR</b>	Uputstvo za upotrebu / Uputstvo za montažu	<b>26</b>
<b>NO</b>	Bruksanvisning / Montasjeveiledning	<b>27</b>
<b>BG</b>	Инструкция за употреба / Ръководство за монтаж	<b>28</b>
<b>SQ</b>	Udhëzuesi i përdorimit / Udhëzime rreth montimit	<b>29</b>
<b>AR</b>	دليل الاستخدام / تعليمات التجميع	<b>30</b>

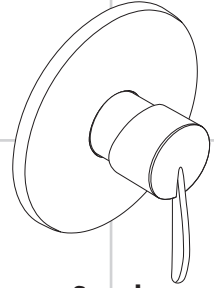

**Starck**  
10615000  
10615003

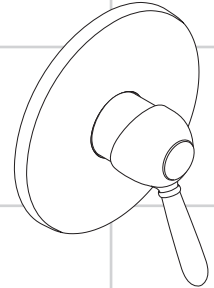

**Carlton**  
17615XXX

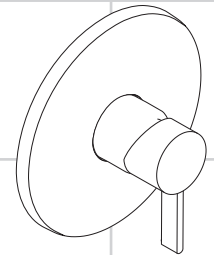

**Steel**  
35625800



## Sicherheitshinweise

- ⚠ Bei der Montage müssen zur Vermeidung von Quetsch- und Schnittverletzungen Handschuhe getragen werden.
- ⚠ Das Produkt darf nur zu Bade-, Hygiene- und Körperreinigungszwecken eingesetzt werden.
- ⚠ Große Druckunterschiede zwischen den Kalt- und Warmwasseranschlüssen müssen ausgeglichen werden.

## Montagehinweise

- Die Armatur muss nach den gültigen Normen montiert, gespült und geprüft werden.
- Vor der Montage muss das Produkt auf Transportschäden untersucht werden. Nach dem Einbau werden keine Transport- oder Oberflächenschäden anerkannt.

## Technische Daten

Betriebsdruck: max. 1 MPa  
 Empfohlener Betriebsdruck: 0,1 – 0,5 MPa  
 Prüfdruck: 1,6 MPa  
 (1 MPa = 10 bar = 147 PSI)  
 Heißwassertemperatur: max. 80 °C  
 Empfohlene Heißwassertemperatur: 65 °C

Hansgrohe Armaturen können in Verbindung mit hydraulisch und thermisch gesteuerten Durchlauferhitzern eingesetzt werden, wenn der Fließdruck mindestens 0,15 MPa beträgt.

Das Produkt ist ausschließlich für Trinkwasser konzipiert!

## Symbolerklärung



Kein essigsäurehaltiges Silikon verwenden!



## Justierung

Einhandmischer mit Warmwasserbegrenzung, Justierung siehe Seite 36. In Verbindung mit Durchlauferhitzern ist eine Warmwassersperre nicht notwendig.



**Maße** (siehe Seite 33)



**Durchflussdiagramm** (siehe Seite 33)



**Bedienung** (siehe Seite 37)



## Reinigung

Reinigung siehe beiliegende Broschüre.



**Serviceteile** (siehe Seite 38)

XXX = Farbcodierung

000 = chrom

090 = chrom/gold-optik

800 = edelstahl-optik



**Prüfzeichen** (siehe Seite 35)

## Störung

## Ursache

## Abhilfe



Armatur schwergängig	- Kartusche defekt, verkalkt	- Kartusche austauschen
Armatur tropft	- Kartusche defekt, Ablagerungen	- Kartusche austauschen
Zu niedrige Warmwassertemperatur, kein Kaltwasser. Durchlauferhitzer springt an, wenn Kaltwasser angewählt wird.	- Warmwasserbegrenzung falsch eingestellt - Kreuzfluss	- Warmwasserbegrenzung einstellen - Kartusche austauschen



**Montage siehe Seite 32**



## Consignes de sécurité

-  Lors du montage, porter des gants de protection pour éviter toute blessure par écrasement ou coupure.
-  Le système de douche ne doit servir qu'à se laver et à assurer l'hygiène corporelle.
-  Il est conseillé d'équilibrer les pressions de l'eau chaude et froide.

## Instructions pour le montage

- La robinetterie doit être installée, rincée et contrôlée conformément aux normes valables.
- Avant son montage, s'assurer que le produit n'a subi aucun dommage pendant le transport. Après le montage, tout dommage de transport ou de surface ne pourra pas être reconnu.

## Informations techniques

Pression de service autorisée: max. 1 MPa  
 Pression de service conseillée: 0,1 - 0,5 MPa  
 Pression maximum de contrôle: 1,6 MPa  
 (1 MPa = 10 bar = 147 PSI)  
 Température d'eau chaude: max. 80 °C  
 Température recommandée: 65 °C

Les mitigeurs Hansgrohe fonctionnent également en association à des chauffe-eau à commande hydraulique ou thermique à condition que la pression soit au minimum de 0,15 MPa.

Le produit est exclusivement conçu pour de l'eau potable!

## Description du symbole



Ne pas utiliser de silicone contenant de l'acide acétique!



## Étalonnage

Mitigeur avec limitation de la température: consulter la page 36 pour le réglage. Une limitation de la température n'est pas nécessaire quand le mitigeur est alimenté par un chauffe-eau instantané.



## Dimensions (voir page 33)



## Diagramme du débit (voir page 33)



## Instructions de service (voir page 37)



## Nettoyage

Pour les conseils d'entretien, voir la brochure ci-jointe.



## Pièces détachées (voir pages 38)

XXX = Couleurs

000 = chromé

090 = chromé/or l'optique

800 = stainless steel optic



## Classification acoustique et débit (voir page 35)

## Dysfonctionnement

## Origine

## Solution

Durété de fonctionnement	- Cartouche défectueuse, entartrée	- Changer la cartouche
Le mitigeur goutte	- Cartouche défectueuse, entartrée	- Changer la cartouche
Température d'eau chaude trop basse, pas d'eau froide. Le chauffe-eau instantané met en route quand on puise de l'eau froide.	- Limiteur de température mal positionné	- Positionner le limiteur de température
	- Flux inversé	- Changer la cartouche



**Montage voir page 32**



## Safety Notes

- Gloves should be worn during installation to prevent crushing and cutting injuries.
- The shower system may only be used for bathing, hygienic and body cleansing purposes.
- The hot and cold supplies must be of equal pressures.

## Installation Instructions

- The fitting must be installed, flushed and tested after the valid norms.
- Prior to installation, inspect the product for transport damages.  
After it has been installed, no transport or surface damage will be honoured.

## Technical Data

Operating pressure:	max. 1 MPa
Recommended operating pressure:	0,1 – 0,5 MPa
Test pressure:	1,6 MPa
(1 MPa = 10 bar = 147 PSI)	
Hot water temperature:	max. 80 °C
Recommended hot water temp.:	65 °C

Hansgrohe mixers can be used together with hydraulically and thermally controlled continuous flow heaters if the flow pressure is at least 0,15 MPa.

The product is exclusively designed for drinking water!

## Symbol description



Do not use silicone containing acetic acid!



## Adjustment

To adjust the hot water limiter on single lever mixers, please see page 36. No adjustment is necessary when using a continuous flow water heater.

## Dimensions (see page 33)



## Flow diagram (see page 33)



## Operation (see page 37)

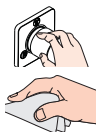

## Cleaning

Cleaning recommendations, see enclosed brochure.

## Spare parts (see page 38)



XXX = Colors

000 = chrome plated

090 = chrome plated/gold plated

800 = stainless steel optic

## Test certificate (see page 35)





Fault	Cause	Remedy
Mixer stiff	- Cartridge defective, calcified	- Exchange cartridge
Mixer dripping	- Cartridge defective, sedimentation	- Exchange cartridge
Hot water temperature too low, no cold water. Instantaneous water heater starts up when cold water is selected.	- Hot water limiter incorrectly set	- Set hot water limiter
	- Crossflow	- Exchange cartridge



**Assembly see page 32**



## **Indicazioni sulla sicurezza**

-  Durante il montaggio, per evitare ferite da schiacciamento e da taglio bisogna indossare guanti protettivi.
-  Il sistema doccia deve essere utilizzato esclusivamente per l'igiene del corpo.
-  Attenzione! Compensare le differenze di pressione tra i collegamenti dell'acqua fredda e dell'acqua calda.

## **Istruzioni per il montaggio**

- La rubinetteria deve essere installata, pulita e testata secondo le istruzioni riportate!
- Prima del montaggio è necessario controllare che non ci siano stati danni durante il trasporto. Una volta eseguito il montaggio, non verranno riconosciuti eventuali danni di trasporto o delle superfici.

## **Dati tecnici**

Pressione d'uso:	max. 1 MPa
Pressione d'uso consigliata:	0,1 - 0,5 MPa
Pressione di prova:	1,6 MPa
(1 MPa = 10 bar = 147 PSI)	
Temperatura dell'acqua calda:	max. 80 °C
Temp. dell'acqua calda consigliata:	65 °C

I miscelatori Hansgrohe possono venire usati con caldaie a "bassa pressione" se la pressione di flusso è almeno di 0,15 MPa.

Il prodotto è concepito esclusivamente per acqua potabile!

## **Descrizione simbolo**



Non utilizzare silicone contenente acido acetico!



### **Taratura**

Regolazione del limitatore di erogazione di acqua calda dei miscelatori monocomando, vedere pagina 36. In combinazione con le caldaie istantanee, il limitatore di erogazione di acqua calda non è necessario.



### **Ingombri (vedi pagg. 33)**



### **Diagramma flusso (vedi pagg. 33)**



### **Procedura (vedi pagg. 37)**



### **Pulitura**

Suggerimenti per la pulizia: vedi il prospetto accluso.



### **Parti di ricambio (vedi pagg. 38)**

XXX = Trattamento

000 = cromato

090 = cromo/dorato ottica

800 = acciaio inox acciaio





### **Segno di verifica (vedi pagg. 35)**

<b>Problema</b>	<b>Possibile causa</b>	<b>Rimedio</b>
Miscelatore duro	- Cartuccia difettosa	- Sostituire la cartuccia
Miscelatore gocciola	- cartuccia difettosa	- Sostituire la cartuccia
Temperatura dell'acqua calda troppo bassa, niente acqua fredda, caldaia istantanea si accende quando si seleziona acqua fredda	- Limitazione dell'acqua calda regolata male	- Regolare la limitazione dell'acqua calda
	- Flusso incrociato	- Sostituire la cartuccia





## Indicaciones de seguridad

-  Durante el montaje deben utilizarse guantes para evitar heridas por aplastamiento o corte.
-  La grifería solo debe ser utilizada para fines de baño, higiene y limpieza corporal.
-  Grandes diferencias de presión en servicio entre agua fría y agua caliente deben equilibrarse.

## Indicaciones para el montaje

- El grifo tiene que ser instalado, probado y testado, según las normas en vigor.
- Antes del montaje se debe examinarse el producto contra daños de transporte. Después de la instalación so se reconoce ningún daño de transporte o de superficie.

## Datos técnicos

Presión en servicio:	max. 1 MPa
Presión recomendada en servicio:	0,1 - 0,5 MPa
Presión de prueba:	1,6 MPa
(1 MPa = 10 bar = 147 PSI)	
Temperatura del agua caliente:	max. 80 °C
Temp. recomendada del agua caliente:	65 °C

Los mezcladores Hansgrohe pueden ser utilizados junto con calentadores continuos de agua que sean manejados de manera hidráulica o térmica, siempre que la presión en servicio ascienda a un mínimo de 0,15 MPa.

El producto ha sido concebido exclusivamente para agua potable.

## Descripción de símbolos



No utilizar silicona que contiene ácido acético!



### Ajuste

Uso como mezclador monomando con limitación del caudal de agua caliente: ver ajuste en página 36. En combinación con calentadores instantáneos no es necesario limitar el caudal de agua caliente.



### Dimensiones (ver página 33)



### Diagrama de circulación (ver página 33)



### Manejo (ver página 37)



### Limpiar

Para las instrucciones de limpieza, ver el folleto adjunto.



### Repuestos (ver página 38)

XXX = Acabados

000 = cromado

090 = cromo/oro óptica

800 = acero especial



### Marca de verificación (ver página 35)

Problema	Causa	Solución
Manecilla va dura	- cartucho dañado	- cambiar el cartucho
Grifo pierde agua	- cartucho calcificado / dañado	- cambiar el cartucho
Temperatura del agua demasiado baja no hay agua fría calentador se dispara al abrir agua fría	- tope de agua caliente mal	- ajustar tope
	- Flujo cruzado	- cambiar el cartucho





## Veiligheidsinstructies

- ⚠ Bij de montage moeten ter voorkoming van kniel- en snijwonden handschoenen worden gedragen.
- ⚠ Het douchesysteem mag alleen voor het wassen, hygiënische doeleinden en voor de lichaamreiniging worden gebruikt.
- ⚠ Grote drukverschillen tussen de koud- en warmwatertoevoer dienen vermeden te worden.

## Montage-instructies

- Leidingen doorspoelen volgens Norm. De mengkraan vervolgens monteren en controleren.
- Vóór de montage moet het product gecontroleerd worden op transportschade.  
Na de inbouw wordt geen transport- of oppervlakteschade meer aanvaard.

## Technische gegevens

Werkdruk: max. 1 MPa  
 Aanbevolen werkdruk: 0,1 – 0,5 MPa  
 Getest bij: 1,6 MPa  
 (1 MPa = 10 bar = 147 PSI)

Temperatuur warm water: max. 80 °C  
 Aanbevolen warm water temp.: 65 °C

Hansgrohe kranen kunnen samen met hydraulisch en thermisch gestuurde geisers gebruikt worden indien de uitstroomdruk min. 0,15 MPa bedraagt.

Het product is uitsluitend ontworpen voor drinkwater!

## Symboolbeschrijving



Gebruik geen zuurhoudende silicone!



### Instellen

Eéngreepsmengkranen met warmwaterbegrenzing, instelling zie blz. 36. In combinatie met geisers is een warmwaterbegrenzing niet noodzakelijk.



### Maten (zie blz. 33)



### Doorstroomdiagram (zie blz. 33)



### Bediening (zie blz. 37)



### Reinigen

Reinigingsadvies zie bijgevoegde brochure.



### Service onderdelen (zie blz. 38)

XXX = Kleuren

000 = verchroomd

090 = chroom/verguld-look

800 = RVS-look



### Keurmerk (zie blz. 35)

## Storing

## Oorzaak

## Oplossing



Bediening zwaar	- Kardoes defect of verkalkt	- Kardoes uitwisselen
Mengkraan lekt	- Kardoes defect of vervuild	- Kardoes uitwisselen
Warmwater temperatuur te laag, geen koud water.	- Heetwaterbegrenzer verkeerd ingesteld	- Heetwaterbegrenzer instellen
Doorstroomtoestel springt aan wanneer koud water gekozen is.	- Kruisstroom	- Kardoes uitwisselen



**Montage zie blz. 32**



## Sikkerhedsanvisninger

-  Ved monteringen skal der bruges handsker for at undgå kvæstelser og snitsår.
-  Brusersystemet må kun bruges til bade-, hygiejne og rengøringsformål.
-  Større trykforskelle mellem koldt og varmt vand bør udjævnes.

## Monteringsanvisninger

- Ifølge gældende regler, skal armaturet monteres, skylles igennem og afprøves.
- Før monteringen skal produktet kontrolleres for transportskader. Efter monteringen godkendes transportskader eller skader på overfladen ikke længere.

## Tekniske data

Driftstryk:	max. 1 MPa
Anbefalet driftstryk:	0,1 – 0,5 MPa
Prøvetryk:	1,6 MPa
(1 MPa = 10 bar = 147 PSI)	
Varmtvandstemperatur:	max. 80 °C
Anbefalet varmtvandstemperatur:	65 °C

Hansgrohe armaturer kan anvendes i forbindelse med hydraulisk- og termiskstyrede gennemstrømningsvandvarmere ved et vandtryk på 0,15 MPa.

Produktet er udelukkende beregnet til drikkevand!

## Symbolbeskrivelse



Der må ikke benyttes eddikesyreholdig silikone!



## Forindstilling

Etgrebsarmaturer med varmtvandsbegrænsning, justering se side 36. I forbindelse med gennemstrømningsvandvarmer er en varmtvandsbegrænsning ikke nødvendig.



## Målene (se s. 33)



## Gennemstrømningsdiagram (se s. 33)



## Brugsanvisning (se s. 37)



## Rengøring

For anbefalinger til rengøringen, se venligst den vedlagte brochure.



## Reserve dele (se s. 38)

XXX = Overflade

000 = Krom

090 = Krom/guld optic

800 = Stainless steel optic



## Godkendelse (se s. 35)



Fejl	Årsag	Hjælp
Grebet går trægt	- Kartusche defekt, tilkalket	- Udskift kartusche
Armaturet drypper	- Defekt eller tilkalket kartusche	- Udskift kartusche
For lav varmtvandstemperatur. Ingen koldt vand. Vandvarmeren starter, når der åbnes for det kolde vand.	- Varmtvandsbegrænsningen er forkert indstillet - Kryds-flow	- Indstil varmtvandsbegrænsningen - Udskift kartusche







## Avisos de segurança

-  Durante a montagem devem ser utilizadas luvas de protecção, de modo a evitar ferimentos resultantes de entalamentos e de cortes.
-  O sistema de duche só pode ser utilizado para fins de higiene pessoal.
-  Grandes diferenças entre as pressões das águas quente e fria devem ser compensadas.

## Avisos de montagem

- A misturadora deve ser instalada, purgada e testada de acordo com as normas em vigor.
- Antes da montagem deve-se controlar o produto relativamente a danos de transporte. Após a montagem não são aceites quaisquer danos de transporte ou de superfície.

## Dados Técnicos

Pressão de funcionamento:	max. 1 MPa
Pressão de func. recomendada:	0,1 – 0,5 MPa
Pressão testada:	1,6 MPa
(1 MPa = 10 bar = 147 PSI)	
Temperatura da água quente:	max. 80 °C
Temp. água quente recomendada:	65 °C

As misturadoras Hansgrohe podem ser utilizadas com esquentadores (de controlo térmico ou hidráulico) desde que a pressão de utilização seja, no mínimo, de 0,15 MPa.

Este produto foi única e exclusivamente concebido para água potável!

## Descrição do símbolo



Não utilizar silicone que contenha ácido acético!



## Afinação

Misturadora monocomando equipada com limitador de temperatura (vide pág. 36). Em combinação com caldeira ou esquentador instantâneo o limitador de água quente não se aplica.



## Medidas (ver página 33)



## Fluxograma (ver página 33)



## Funcionamento (ver página 37)



## Limpeza

Consultar a seguinte brochura sobre as recomendações de limpeza.



## Peças de substituição (ver página 38)

XXX = Acabamentos

000 = cromado

090 = cromado/ouro ótica

800 = aço imaculado ótica





## Marca de controlo (ver página 35)

Falha	Causa	Solução
Misturadora perra	- Cartucho defeituoso, calcificado	- Substituir o cartucho
Misturadora a pingar	- Manga da esfera defeituosa	- Substituir o cartucho
Temperatura da água quente muito baixa, sem água fria. O esquentador dispara quando a água fria está seleccionada.	- O limitador de temperatura está incorrectamente colocado	- Regular o limitador de temperatura
	- Fluxo cruzado	- Substituir o cartucho





## Wskazówki bezpieczeństwa

-  Aby uniknąć zranień, takich jak zgniecenia czy przecięcia, podczas montażu należy nosić rękawice.
-  Pysznic może być używany tylko do kąpieli, higieny i czyszczenia ciała.
-  Znaczne różnice ciśnień na dopływach ciepłej i zimnej wody muszą zostać wyrównane.

## Wskazówki montażowe

- Armatura musi być zamontowana, przepłukana i wypróbowana według obowiązujących norm.
- Przed montażem należy skontrolować produkt pod kątem szkód transportowych.  
Po montażu nie widać żadnych szkód transportowych ani szkód na powierzchni.

## Dane techniczne

Ciśnienie robocze:	maks. 1 MPa
Zalecane ciśnienie robocze:	0,1 - 0,5 MPa
Ciśnienie próbne:	1,6 MPa
(1 MPa = 10 bary = 147 PSI)	
Temperatura wody gorącej:	maks. 80 °C
Zalecana temperatura wody gorącej:	65 °C

Armatura Hansgrohe może być stosowana z przepływowymi podgrzewaczami wody sterowanymi hydraulicznie i termicznie w przypadku, gdy ciśnienie przepływu wynosi co najmniej 0,15 MPa.

Produkt stworzono wyłącznie do wody pitnej!

## Opis symbolu



Nie stosować silikonów zawierających kwas octowy!



## Ustawianie

Mieszacz jednocyfrowy z ogranicznikiem temperatury wody, ustawianie, patrz str. 36. W połączeniu z przepływowym podgrzewaczem wody ogranicznik temperatury wody nie jest konieczny.

## Wymiary (patrz strona 33)



## Schemat przepływu (patrz strona 33)



## Obsługa (patrz strona 37)



## Czyszczenie

Zalecenie dotyczące pielęgnacji, patrz dołączona broszura.



## Części serwisowe (patrz strona 38)



XXX = kody wykończenia powierzchni

000 = chrom

090 = chrom/złoty szlachetna

800 = stal szlachetna

## Znak jakości (patrz strona 35)



### Usterka

### Przyczyna

### Pomoc



Uchwyt armatury pracuje z wysiłkiem	- Uszkodzony wkład, zakamieniony	- Wymiana wkładu
Armatura cieknie	- Uszkodzony wkład, osady	- Wymiana wkładu
Za niska temperatura ciepłej wody, brak zimnej wody. Przepływowo podgrzewacz wody uruchamia się, gdy wybiera się zimną wodę.	- Niewłaściwe ustawienie ogranicznik ciepłej wody - Przepływ krzyżowy	- Ustawić ogranicznik ciepłej wody - Wymiana wkładu



## Montaż patrz strona 32



## Bezpečnostní pokyny

-  Pro zabránění řezným zraněním a pohmožděním je nutné při montáži nosit rukavice.
-  Produkt smí být používán pouze ke koupání a za účelem tělesné hygieny.
-  Je nutné vyrovnat velké rozdíly tlaku mezi přípoji studené a teplé vody.

## Pokyny k montáži

- Armatura se musí montovat, proplachovat a testovat podle platných norem.
- Před montáží je třeba produkt zkontrolovat, zda nebyl při transportu poškozen.  
Po zabudování nebudou uznány žádné škody způsobené transportem nebo poškození povrchu.

## Technické údaje

Provozní tlak:	max. 1 MPa
Doporučený provozní tlak:	0,1 – 0,5 MPa
Zkušební tlak:	1,6 MPa
(1 MPa = 10 bar = 147 PSI)	
Teplota horké vody:	max. 80 °C
Doporučená teplota horké vody:	65 °C

Armatury Hansgrohe je možno používat v kombinaci s hydraulicky a tepelně řízenými průtokovými ohřívači v případě, že tlak činí minimálně 0,15 MPa.

Výrobky Hansgrohe jsou vhodné pro přímý kontakt s pitnou vodou.

## Popis symbolů



Nepoužívat silikon s obsahem kyseliny octové!



## Nastavení

Páková baterie s omezením horké vody, seřízení viz. str. 36. Ve spojení s průtokovými ohřívači není uzávěr teplé vody nutný.



## Rozměry (viz strana 33)



## Diagram průtoku (viz strana 33)



## Ovládání (viz strana 37)



## Čištění

Doporučení k čištění viz příložená brožura.



## Servisní díly (viz strana 38)

XXX = kód povrchové úpravy

000 = chrom

090 = chrom/zlato ocel

800 = nerezová ocel



## Zkušební značka (viz strana 35)



Porucha	Příčina	Odstranění
Armatura jde ztěžka	- Kartuše je vadná, zanesená vodním kamenem	- Kartuši vyměnit
Armatura odkapává	- kartuše je vadná, usazeniny	- Kartuši vyměnit
nízká teplota teplé vody .žádná studená voda průtokový ohřívač naskočí, když se navolí studená voda	- Špatně nastavená zarážka pro teplou vodu - Křížení toků	- Seřídit zarážku pro teplou vodu - Kartuši vyměnit



## Montáž viz strana 32



## Bezpečnostné pokyny

-  Pri montáži musíte nosiť rukavice, aby ste predišli pomliaždeninám a rezným poraneniam.
-  Produkt sa smie používať len na kúpanie a telesnú hygienu.
-  Veľké rozdiely v tlaku medzi prípojkami studenej a teplej vody musia byť vyrovnané.

## Pokyny pre montáž

- Armatúra sa musí montovať, preplachovať a testovať podľa platných noriem.
- Pred montážou musíte produkt skontrolovať, či nebol počas transportu poškodený.  
Po zabudovaní nebudú uznané žiadne škody spôsobené transportom alebo poškodenia povrchu.

## Technické údaje

Prevádzkový tlak:	max. 1 MPa
Doporučený prevádzkový tlak:	0,1 – 0,5 MPa
Skúšobný tlak:	1,6 MPa
(1 MPa = 10 bar = 147 PSI)	
Teplota teplej vody:	max. 80 °C
Doporučená teplota teplej vody:	65 °C

Batérie Hansgrohe môžete používať v spojení s hydraulickými a tepelne ovládanými prietokovými ohrievačmi, ak je tlak minimálne 0,15 MPa.

Výrobok je koncipovaný výhradne pre pitnú vodu!

## Popis symbolov



Nepoužívať silikón s obsahom kyseliny octovej!



## Nastavenie

Páková batéria s obmedzením teplej vody, nastavenie vid' str. 36. V spojení s prietokovými ohrievačmi nie je uzáver teplej vody nutný.



**Rozmery** (vid' strana 33)



**Diagram prietoku** (vid' strana 33)



**Obsluha** (vid' strana 37)



## Čistenie

Odporúčanie o čistení nájdete v priloženej brožúre.



**Servisné diely** (vid' strana 38)

XXX = kód povrchovej úpravy

000 = chróm

090 = chróm/zlato ocel

800 = ušľachtilá ocel



**Osvedčenie o skúške** (vid' strana 35)

## Porucha

## Príčina

## Pomoc

Armatúra "chodí" ťažko	- Kartuša je poškodená, vápenaté usadeniny	- Vymeniť kartušu
Z armatúry kvapká voda	- Chybná kartuša, usadeniny	- Vymeniť kartušu
Málo teplá voda, žiadna studená voda, prietokový ohrievač naskočí, keď sa navolí studená voda.	- Nesprávne nastavená zarážka na teplú vodu - Križenie tokov	- Nastavenie zarážky na teplú vodu - Vymeniť kartušu





## ⚠️ 安全技巧

- △ 装配时为避免挤压和切割受伤，必须戴上手套。
- △ 淋浴系统只允许作为洗浴、卫生和洁身之用。
- △ 冷热水管间过大的压力差必须予以平衡。

## 安装提示

- 必须按照现行的规定安装，冲洗和测试产品。
- 安装前必须检查产品是否受到运输损害。  
安装后将不认可运输损害或表面损伤。

## 技术参数

工作压强:	最大 1 MPa
推荐工作压强:	0,1 - 0,5 MPa
测试压强:	1,6 MPa
(1 MPa = 10 bar = 147 PSI)	
热水温度:	最大 80° C
推荐热水温度:	65° C

如果水压达到0,15 MPa以上，汉斯格雅双手柄龙头可以和液压式或热控式连续流热水器一起使用。

该产品专为饮用水设计！

## 符号说明



请勿使用含有乙酸的硅！



## 调节

带有热水控制器的单手柄龙头的调节方法，参见第 36 页。如果与连续流热水器一起使用，则不必作任何调节。



大小 (参见第 33 页)



## 流量示意图

(参见第 33 页)



操作 (参见第 37 页)



## 清洗

清洁建议参见附入的小册子。



备用零件 (参见第 38 页)

XXX = 颜色代码

000 = 镀铬

090 = 镀铬/黑色

800 = 不锈钢表面



检验标记 (参见第 35 页)

问题	原因	补救
龙头不灵活	- 滤筒损坏，结垢	- 更换滤筒
龙头滴水	- 滤筒损坏，沉淀	- 更换滤筒
热水温度过低，没有冷水。选择冷水时，热水器启动。	- 热水控制器设置错误	- 设置热水控制器
	- 交叉流动	- 更换滤筒



安装 参见第 32 页



## Указания по технике безопасности

- ⚠ Во время монтажа следует надеть перчатки во избежание прищемления и порезов.
- ⚠ Изделие разрешается использовать только в гигиенических целях: для принятия ванны и личной гигиены.
- ⚠ донного клапа. Перед установкой смесителя необходимо регулировочными кранами выровнять давление холодной и горячей воды при помощи вентилей регулирующих подачу воды в квартиру.

## Указания по монтажу

- Смеситель должен быть смонтирован по действующим нормам и в соответствии с настоящей инструкцией, проверен на герметичность и безупречность работы.
- Перед монтажом следует проверить изделие на предмет повреждений при перевозке. После монтажа претензии о возмещении ущерба за повреждения при перевозке или повреждения поверхностей не принимаются.

## Технические данные

Рабочее давление:	не более. 1 МПа
Рекомендуемое рабочее давление:	0,1 – 0,5 МПа
Давление:	1,6 МПа
(1 МПа = 10 bar = 147 PSI)	
Температура горячей воды:	не более. 80 °С
Рекомендуемая темп. гор. воды:	65 °С

Арматуры Hansgrohe могут использоваться в комбинации с проточными нагревателями с гидравлическим и термическим управлением, если давление истечения составляет не менее 0,15 МПа.

Изделие предназначено исключительно для питьевой воды!

## Неисправность

## Причина

## Устранение неисправности

Арматура работает с усилием	- Картридж неисправен, засорение накипью	- Замените картридж
Арматура протекает	- Картридж неисправен, отложения	- Замените картридж
Слишком низкая температура горячей воды. Проточный нагреватель запускается при выборе холодной воды.	- Ограничение горячей воды отрегулировано неправильно	- Отрегулируйте ограничение горячей воды
	- Перекрестный поток	- Замените картридж

## Описание символов



Не применяйте силикон, содержащий искусственную кислоту.



## Подгонка

Однорычажный смеситель имеет ограничитель расхода горячей воды (см. Стр. 36: юстировка). В комбинации с проточными нагревателями не разрешается установка блокировка горячей воды!

## Размеры (см. стр. 33)



## Схема потока

(см. стр. 33)



## Эксплуатация (см. стр. 37)



## Очистка

Рекомендации по очистке см. в прилагаемой брошюре.



## Комплект (см. стр. 38)

XXX = Код цвета поверхности  
 000 = хром  
 090 = хром/глянцевое золото  
 800 = сталь



## Знак технического контроля

(см. стр. 35)





## Biztonsági utasítások

- ⚠ A szerelésnél a zúzódások és vágási sérülések elkerülése érdekében kesztyűt kell viselni.
- ⚠ A terméket csak fürdéshez, mosakodáshoz, és egészségügyi tisztálkodáshoz szabad használni.
- ⚠ A hidegvíz- és a melegvíz-csatlakozások közötti nagy nyomáskülönbséget kikell egyenlíteni!

## Szerelési utasítások

- A csaptelepet az érvényben lévő előírásoknak megfelelően kell felszerelni, átöblíteni és ellenőrizni.
- A szerelés előtt ellenőrizni kell, hogy a terméknek nincs-e szállítási sérülése.  
Beépítés után a szállítási- vagy felületi sérüléseket nem ismerik el.

## Műszaki adatok

Üzemi nyomás:	max. 1 MPa
Ajánlott üzemi nyomás:	0,1 – 0,5 MPa
Nyomáspróba:	1,6 MPa
(1 MPa = 10 bar = 147 PSI)	
Forróvíz hőmérséklet:	max. 80 °C
Forróvíz javasolt hőmérséklete:	65 °C

A Hansgrohe csaptelepek hidraulikus és termikus vezérlésű átfolyós melegítővel kapcsolatban is használhatóak, ha az átfolyó nyomás legalább 0,15 MPa.

A terméket kizárólag ivóvízhez tervezték!

## Szimbólumok leírása



Ne használjon ecetsavtartalmú szilikon!



## Beállítás

Az egykaros, melegvíz-korlátozóval ellátott keverő csaptelep beállítását lásd a 36. oldalon. Az átfolyó rendszerű vízmelegítőknél nem szükséges a melegvíz- korlátozó.



**Méretet** (lásd a 33. oldalon)



**Átfolyási diagram** (lásd a 33. oldalon)

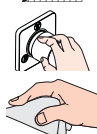

**Használat** (lásd a 37. oldalon)

## Tisztítás

Az ajánlott tisztításhoz lásd a mellékelt brosúrát.



**Tartozékok** (lásd a 38. oldalon)

XXX = Színkódok

000 = króm

090 = króm/arany-hatású

800 = acéloptika



**Vizsgajel** (lásd a 35. oldalon)

Hiba	Ok	Megoldás
Nehezen nyitható a csap.	- A kerámiabetét meghibásodott, elvízkövesedett.	- A kerámiabetétet ki kell cserélni.
Csőpög a csap.	- A kerámiabetét meghibásodott, lerakódások	- A kerámiabetétet ki kell cserélni.
Túl alacsony melegvíz hőmérséklet, nincs hidegvíz. A hidegvíz kiválasztásakor beindul az átfolyós melegítő.	- A melegvíz szabályozó rosszul van beállítva. - Keresztfolyás	- A melegvíz szabályozót újra be kell állítani. - A kerámiabetétet ki kell cserélni.



**Szerelés lásd a 32. oldalon**



## Turvallisuusohjeet

- ⚠ Asennuksessa on käytettävä käsineitä puristumien ja viiltojen aiheuttamien tapaturmien estämiseksi.
- ⚠ Suihkujärjestelmää saa käyttää ainoastaan kylpy-, hygienia- ja puhdistustarkoituksiin.
- ⚠ Suuret paine-erot kylmä- ja kuumavesiliitäntöjen välillä on tasattava.

## Asennusohjeet

- Kaluste on asennettava, huuhdeltava ja tarkastettava voimassa olevien määräysten mukaisesti.
- Ennen asennusta on tarkastettava tuotteen mahdolliset kuljetusvahingot. Asennuksen jälkeen kuljetus- ja pintavaurioita ei hyväksytä.

## Tekniset tiedot

Käyttöpaine:	maks. 1 MPa
Suosittelut käyttöpaine:	0,1 – 0,5 MPa
Koestuspaine:	1,6 MPa
(1 MPa = 10 bar = 147 PSI)	
Kuuman veden lämpötila:	maks. 80 °C
Kuuman veden suosituslämpötila:	65 °C

Hansgrohe kalusteita voi käyttää hydraulisesti tai termisesti ohjattujen läpivirtauskuumentimien yhteydessä, jos virtauspaine on vähintään 0,15 MPa.

Tuote on suunniteltu käytettäväksi ainoastaan juomaveden kanssa!

## Merkin kuvaus



Älä käytä etikkahappopitoista silikonia!



## Säätö

Yksivipuinen sekoittaja lämpimän veden rajoituksella, katso säätö sivulta 36. Lämpimän veden rajoitusta ei tarvita läpivirtauskuumentimen yhteydessä.



## Mitat (katso sivu 33)



## Virtausdiagrammi (katso sivu 33)

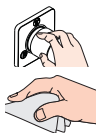

## Käyttö (katso sivu 37)

## Puhdistus

Katso puhdistussuositus mukana olevasta esitteestä.



## Varaosat (katso sivu 38)

XXX = Värikoodi

000 = kromi

090 = kromi/kultaoptiikka

800 = inox-optinen



## Koestusmerkki (katso sivu 35)

## Häiriö

## Syy

## Toimenpide

Hana on raskaskäyttöinen	- Patruuna rikki, kalkkikerrostumia	- Vaihda patruuna
Hanasta tippuu vettä	- Patruuna rikki, kerrostumia	- Vaihda patruuna
Lämminveden lämpötila liian alhainen, ei kylmää vettä.	- Lämminveden rajoitin väärin säädetty	- Säädä lämminveden rajoitin
Lämpötila laskee läpivirtauskuumentimen käynnistyessä kylmää vettä otettaessa.	- Ristiinvirtaus	- Vaihda patruuna







## ⚠ Säkerhetsanvisningar

- ⚠ Handskar ska bäras under monteringsarbetet så att man kan undvika kläm- och skärskadorna werden.
- ⚠ Produkten får bara användas till kroppshygien med bad och dusch.
- ⚠ Stora tryckskillnader mellan anslutningarna för varmt och kallt vatten måste utjämnas.

## Monteringsanvisningar

- Armaturen måste installeras, genomspolas och testas enligt gällande föreskrifter.
- Det måste undersökas om produkten har transportskador innan den monteras.  
Efter monteringen accepteras inga transport- eller ytskiktsskador.

## Tekniska data

Driftstryck:	max. 1 MPa
Rek. driftstryck:	0,1 – 0,5 MPa
Tryck vid provtryckning: (1 MPa = 10 bar = 147 PSI)	1,6 MPa
Varmvattentemperatur:	max. 80 °C
Rek. varmvattentemp.:	65 °C

Hansgrohe blandare kan användas tillsammans med hydrauliskt och termiskt styrda varmvattenberedare när flödestrycket uppgår till minst 0,15 MPa.

Produkten är enbart avsedd för dricksvatten!

## Symbolförklaring



Använd inte silikon som innehåller ättiksyra!



## Justering

Enhandsblandare med varmvattenreglering, justering se sidan 36. Vid användning tillsammans med varmvattenberedare behövs ingen varmvattenreglering.



## Måtten (se sidan 33)



## Flödesschema (se sidan 33)



## Hantering (se sidan 37)



## Rengöring

Se den medföljande broschyren för rengöringsrekommendation



## Reservdelar (se sidan 38)

XXX = Färgkodning

000 = krom

090 = krom/guld-optik

800 = rostfri-optik



## Testsigill (se sidan 35)

## Störning

## Orsak

## Åtgärd

Blandare är trög	- Patron defekt, förkalkad	- Byt ut patron
Blandare droppar	- Patron defekt, avlagringar	- Byt ut patron
För låg varmvattentemperatur, inget kallvatten.	- Varmvattenreglering felaktigt inställd	- Ställ in varmvattenreglering
Varmvattenberedaren slår på när kallvatten väljs.	- Korsflöde	- Byt ut patron



**Montering se sidan 32**



## Saugumo technikos nurodymai

- ⚠️ Apsaugai nuo užspaudimo ir įsijovimo montavimo metu mūvėkite pirštines.
- ⚠️ Gaminys turi būti naudojamas tik maudymuisi, kūno higienai ir švarai palaikyti.
- ⚠️ Turi būti išlyginti šalto ir karšto slėgio nelygumai.

## Montavimo instrukcija

- Maišytuvus privalo būti montuojamas ir išbandomas pagal veikiančias normas ir šią instrukciją.
- Prieš montuojant būtina patikrinti, ar gaminys nebuvo pažeistas transportavimo metu. Sumontavus pretenzijos dėl transportavimo ir paviršiaus pažeidimų nepriimamos.

## Techniniai duomenys

Darbinis slėgis: ne daugiau kaip 1 MPa  
 Rekomenduojamas slėgis: 0,1 – 0,5 MPa  
 Bandomasis slėgis: 1,6 MPa  
 (1 MPa = 10 barų = 147 PSI)  
 Karšto vandens temperatūra: ne daugiau kaip 80 °C  
 Rekomenduojama karšto vandens temperatūra: 65 °C

“Hansgrohe” maišytuvai gali būti naudojami su hidrauliškai ir termiškai reguliuojamais momentiniais šildikliais, kai vandens slėgis mažesnis kaip 0,15 MPa.

Produktas skirtas tik geriamajam vandeniui!

## Simbolio aprašymas



Nenaudokite silikono, kurio sudėtyje yra acto rūgšties!



## Reguliavimas

Vienos rankenėlės maišytuvus turi karšto vandens ribotuvą (nustatymą žr. psl. 36). Naudojant momentinį šildiklį karšto vandens ribotuvus nebūtinai.



## Išmatavimai (žr. psl. 33)



## Pralaidumo diagrama (žr. psl. 33)



## Eksplotacija (žr. psl. 37)



## Valymas

Valymo rekomendacijas žr. pridedamoje brošiūroje.



## Atsarginės dalys (žr. psl. 38)

XXX = Spalva

000 = chrom

090 = chrominė (aukso optika)

800 = plienas



## Bandymo pažyma (žr. psl. 35)

Gedimas	Priežastis	Priemonė
Sunkiai sukiojama rankenėlė	- Kasetė pažeista, užkalkėjusi	- Pakeisti kasetę
Maišytuvus praleidžia vandenį	- Kasetė pažeista, užkalkėjusi	- Pakeisti kasetę
Per maža karšto vandens temperatūra, nėra šalto vandens.	- Neteisingai nustatytas karšto vandens ribotuvus	- Nustatyti karšto vandens ribotuvą
Momentinis pašildytojas pradeda veikti, kai naudojamas šalta vanduo	- Kryžminė srovė	- Pakeisti kasetę





## Sigurnosne upute

- ⚠ Prilikom montaže se radi sprječavanja prignječenja i posjekotina moraju nositi rukavice.
- ⚠ Proizvod se smije primjenjivati samo za kupanje, tuširanje i osobnu higijenu.
- ⚠ Velika razlika u pritisku između vruće i hladne vode mora biti izbalansirana.

## Upute za montažu

- Cijevi moraju biti postavljene, isprane i testirane prema važećim normama.
- Prije montaže mora se provjeriti je li proizvod oštećen prilikom transporta. Nakon ugradnje se ne priznaju nikakve reklamacije koje se odnose na površinska i transportna oštećenja.

## Tehnički podaci

Najveći dopušteni tlak:	tlak 1 MPa
Preporučeni tlak:	0,1 – 0,5 MPa
Probni tlak:	1,6 MPa
(1 MPa = 10 bar = 147 PSI)	
Temperatura vruće vode:	tlak 80 °C
Preporučena temperatura vruće vode:	65 °C

Hansgrohe armature mogu se koristiti u kombinaciji sa hidraulički i termički kontroliranim protočnim bojlerima ukoliko tlak iznosi najmanje 0,15 MPa

Proizvod je koncipiran isključivo za pitku vodu!

## Opis simbola



Nemojte koristiti silikon koji sadrži octenu kiselinu!



## Regulacija

Da bi podesili limiter vruće vode na jednoručnim slavinama molimo Vas da pogledate stranicu 36. Podešavanje nije potrebno ako koristite protočni bojler.



## Mjere (pogledaj stranicu 33)



## Dijagram protoka (pogledaj stranicu 33)



## Upotreba (pogledaj stranicu 37)



## Čišćenje

Upute za čišćenje nalaze se u priloženoj brošuri.



## Rezervni dijelovi (pogledaj stranicu 38)

XXX = Boje

000 = krom

090 = optika krom/zlato

800 = plemeniti čelik



## Oznaka testiranja (pogledaj stranicu 35)

## Greška

## Uzrok

## Otklanjanje

Ručica se zaglavila	- Neispravan uložak - Taloženje kamenca	- Zamijenite uložak
Slavina kaplje	- Neispravan uložak, naslage kamenca	- Zamijenite uložak
Preniska temperatura vruće vode, nedostatak hladne vode. Protočni bojler se pali pri podešenoj funkciji za protok hladne vode	- Limiter vruće vode nije dobro podešen - Križni tok vode	- Podesite limiter vruće vode - Zamijenite uložak





## ! Güvenlik uyarıları

- ⚠ Montaj esnasında ezilme ve kesilme gibi yaralanmaları önlemek için eldiven kullanılmalıdır.
- ⚠ Duş sistemi yalnızca banyo, hijyen ve beden temizliği amaçları doğrultusunda kullanılabilir.
- ⚠ Sıcak ve soğuk su bağlantıları arasında büyük basınç farklılıkları varsa, bu basınç farklılıklarının dengelenmesi gerekir.

## Montaj açıklamaları

- Batarya monte edilmeli, geçerli normlardan sonra akis testi yapılmalıdır.
- Montaj işleminden önce ürün nakliye hasarları yönünden kontrol edilmelidir.  
Montaj işleminden sonra nakliye veya yüzey hasarları için sorumluluk üstlenilmemektedir.

## Teknik bilgiler

İşletme basıncı:	azami 1 MPa
Tavsiye edilen işletme basıncı:	0,1 - 0,5 MPa
Kontrol basıncı:	1,6 MPa
(1 MPa = 10 bar = 147 PSI)	
Sıcak su sıcaklığı:	azami 80 °C
Tavsiye edilen su ısısı:	65 °C

Hansgrohe bataryaları, akış basıncı en az 0,15 MPa olursa hidrolik ve termik kumandalı şofbenlerle bağlantılı olarak kullanılabilir.

Ürün sadece şebeke suyu için tasarlanmıştır!

## Simge açıklaması



Asetik asit içeren silikon kullanmayın!



## Ayarlama

Sıcak su sınırlayıcı özelliğine sahip tek kollu bataryanın ayarlanması için 36. sayfaya bakınız. Bir sürekli akışlı su ısıtıcısı ile birlikte kullanılırsa sıcak su sınırlayıcısına gerek kalmaz.



## Ölçüleri (Bakınız sayfa 33)



## Akış diyagramı (Bakınız sayfa 33)



## Kullanımı (Bakınız sayfa 37)



## Temizleme

Temizlik önerisi için birlikte verilen broşüre bakınız.



## Yedek Parçalar (Bakınız sayfa 38)

XXX = Renkler

000 = krom

090 = krom/altın-optik

800 = paslanmaz çelik - optik





## Kontrol işareti (Bakınız sayfa 35)

arıza	sebebi	yardımi
Batarya kullanımı ağırlaşıyor	- Kartuş Bozulmuş ve kireçlenmiş olabilir	- Kartuşu değiştirin
Batarya su damlatıyor	- Kartuş arızalı, kireçlenmiş	- Kartuşu değiştirin
Sıcak su sıcaklığı çok düşük, soğuk su yok. Soğuk su seçilince şofben çalışmaya başlıyor.	- Isı limitleyici düzgün çalışmıyor	- Isı limitleyiciyi yeniden ayarlayın
	- Çapraz akış	- Kartuşu değiştirin





## Instrucțiuni de siguranță

-  La montare utilizați mănuși pentru evitarea contuziunilor și tăierii mâinilor.
-  Sistemul de duș poate fi utilizat doar pentru spălarea, menținerea igienei și curățarea corpului.
-  Diferențele de presiune mari între alimentarea cu apă rece și apă caldă trebuie echilibrate.

## Instrucțiuni de montare

- Bateria trebuie montată, clătită și verificată conform normelor în vigoare.
- Înainte de instalare verificați, dacă produsul prezintă deteriorări de transport.  
După instalare garanția nu acoperă deteriorările de transport și cele de suprafață.

## Date tehnice

Presiune de funcționare:	max. 1 MPa
Presiune de funcționare recomandată:	0,1 – 0,5 MPa
Presiune de verificare:	1,6 MPa
(1 MPa = 10 bar = 147 PSI)	
Temperatura apei calde:	max. 80 °C
Temperatura recomandată a apei calde:	65 °C

Bateriile Hansgrohe pot fi utilizate cu boiler instant cu comandă termică sau hidraulică dacă presiunea apei de alimentare este de min. 0,15 MPa.

Produsul este destinat exclusiv pentru apă potabilă.

## Descrierea simbolurilor



Nu utilizați silikon cu conținut de acid acetic!



## Reglare

Bateria monocomadă cu limitarea apei calde, pentru reglare vezi pag. 36. Dacă conectați bateria la un boiler instant nu este necesară instalarea unui opritor de apă caldă.



## Dimensiuni (vezi pag. 33)



## Diagrama de debit (vezi pag. 33)



## Utilizare (vezi pag. 37)



## Curățare

Pentru recomandările referitoare la curățare vezi broșura alăturată.



## Piese de schimb (vezi pag. 38)

XXX = cod de culori

000 = crom

090 = crom/auriu optic

800 = otel inox



## Certificat de testare (vezi pag. 35)

## Deranjament

## Cauza

## Măsurile de remediere

Bateria se mișcă dificil	- Cartuș defect din cauza depunerilor de calcar	- Schimbați cartușul.
Bateria picură	- Cartuș defect din cauza depunerilor	- Schimbați cartușul.
Temperatura apei este prea mică, nu este apă rece. Boilerul instant pornește când se dă drumul la apă rece	- Limitarea temperaturii apei calde setată incorect. - Curgere încrucișată (apa rece în intră în conducta de apă caldă și invers)	- Setaj limitarea temperaturii apei calde. - Schimbați cartușul.



**Montare vezi pag. 32**



## ⚠ Υποδείξεις ασφαλείας

- ⚠ Για να αποφύγετε τραυματισμούς κατά τη συναρμολόγηση πρέπει να φοράτε γάντια.
- ⚠ Το προϊόν επιτρέπεται να χρησιμοποιείται μόνο σαν μέσο λουτρού, υγιεινής και καθαρισμού του σώματος.
- ⚠ Οι διαφορές της πίεσης μεταξύ της σύνδεσης κρύου και ζεστού νερού θα πρέπει να αντισταθμίζονται.

## Οδηγίες συναρμολόγησης

- Η μπαταρία πρέπει να τοποθετηθεί, να πλυθεί και να ελεγχθεί με βάση τους ισχύοντες κανόνες υδραυλικής τέχνης
- Πριν τη συναρμολόγηση πρέπει να εξεταστεί το προϊόν για ζημιές μεταφοράς.  
Μετά την εγκατάσταση δεν αναγνωρίζονται ζημιές από τη μεταφορά ή επιφανειακές ζημιές.

## Τεχνικά Χαρακτηριστικά

Λειτουργία πίεσης:	έως 1 MPa
Συνιστώμενη λειτουργία πίεσης:	0,1 – 0,5 MPa
Πίεση ελέγχου:	1,6 MPa (1 MPa = 10 bar = 147 PSI)
Θερμοκρασία ζεστού νερού:	έως 80 °C
Συνιστώμενη θερμοκρασία ζεστού νερού:	65 °C

Οι βάνες Hansgrohe μπορούν να συνδυαστούν με ταχυθερμοσίφωνες υδραυλικού και θερμικού ελέγχου, όταν η πίεση ροής αριθμεί τουλάχιστον 0,15 MPa.

Το προϊόν έχει σχεδιαστεί αποκλειστικά για πόσιμο νερό!

## Περιγραφή συμβόλων



Μην χρησιμοποιείτε σιλικόνη που περιέχει οξικό οξύ!



### Ρύθμιση

Για να προσαρμόσετε το δοσομετρική ζεστού νερού σε αναμεικτικές μπαταρίες, παρακαλούμε δείτε τη ρύθμιση στη σελ. 36. Δεν είναι απαραίτητη η διάταξη φραγής ζεστού νερού σε συνδυασμό με ταχυθερμοσίφωνα.



### Διαστάσεις (βλ. σελίδα 33)



### Διάγραμμα ροής (βλ. σελίδα 33)



### Χειρισμός (βλ. σελίδα 37)



### Καθαρισμός

Για οδηγίες καθαρισμού βλέπε συνημμένο ενημερωτικό φυλλάδιο.



### Ανταλλακτικά (βλ. σελίδα 38)

XXX = Χρώματα

000 = Επιχρωμιωμένο

090 = Επιχρωμιωμένο/οπτική χρυσού

800 = οπτική ανοξειδώτου χάλυβα



### Σήμα ελέγχου (βλ. σελίδα 35)

## Βλάβη

## Αιτία



## Διόρθωση

Σκληρή μπαταρία (μείκτης)	- Ελαττωματικό φυσίγγιο, άλατα	- Αλλαγή φυσιγγίου
Η μπαταρία στάζει	- Ελαττωματικό φυσίγγιο, καθιζήσεις	- Αλλαγή φυσιγγίου
Χαμηλή θερμοκρασία ζεστού νερού, καθόλου κρύο νερό. Ο ταχυθερμοσίφωνα ενεργοποιείται, όταν επιλέγεται το κρύο νερό.	- Λάθος ρύθμιση της περιοριστικής διάταξης ζεστού νερού - Σταυροειδής ροή	- Ρυθμίστε την περιοριστική διάταξη του ζεστού νερού - Αλλαγή φυσιγγίου





## Varnostna opozorila

-  Pri montaži je treba nositi rokavice, da se prepreči poškodbe zaradi zmečkanja ali urezov.
-  Ta izdelek se sme uporabljati le z namenom umivanja, vzdrževanja higiene in telesne nege.
-  Velike razlike v tlaku med priključkom za mrzlo in priključkom za toplo vodo je potrebno izravnati.

## Instructions pour le montage

- Armaturo je potrebno montirati, splakniti in testirati v skladu z veljavnimi predpisi.
- Pred montažo je treba izdelek preveriti glede morebitnih transportnih poškodb.  
Po vgradnji transportne ali površinske poškodbe ne bodo več priznane.

## Tehnični podatki

Delovni tlak:	maks. 1 MPa
Priporočeni delovni tlak:	0,1 – 0,5 MPa
Preskusni tlak:	1,6 MPa
(1 MPa = 10 bar = 147 PSI)	
Temperatura tople vode:	maks. 80 °C
Priporočena temperatura tople vode:	65 °C

Armature Hansgrohe lahko uporabljate v povezavi s hidravlično in termično uravnanimi pretočnimi grelniki, če je pretočni tlak najmanj 0,15 MPa.

Proizvod je zasnovan izključno za sanitarno vodo!

## Opis simbola



Ne smete uporabiti silikona, ki vsebuje ocetno kislino!



## Justiranje

Enoročne mešalne baterije z omejevalnikom tople vode, za justiranje glejte stran 36. V povezavi s pretočnimi grelniki zapora tople vode ni potrebna.



## Mere (glejte stran 33)



## Diagram pretoka (glejte stran 33)

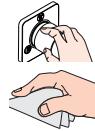

## Upravljanje (glejte stran 37)



## Čiščenje

Priporočilo za čiščenje glejte v priloženi brošuri.



## Rezervni deli (glejte stran 38)

XXX = Barve

000 = krom

090 = krom/pozlačena

800 = videz legiranega jekla



## Preskusni znak (glejte stran 35)

## Napaka

## Vzrok



## Pomoč

Težko premikanje armature	- Pokvarjen vložek, poapneno	- Zamenjajte vložek
Iz armature kaplja	- Pokvarjen vložek, usedline	- Zamenjajte vložek
Prenizka temperatura tople vode, ni mrzle vode. Pretočni grelnik se sproži, kadar izberete mrzlo vodo.	- Omejevalnik tople vode ni pravilno nastavljen - Križni tok	- Nastavite omejevalnik tople vode - Zamenjajte vložek





## Ohutusjuhised

-  Kandke paigaldamisel muljumis- ja löikevigastuste vältimiseks kindaid.
-  Toodet tohib kasutada ainult pesemis-, hügieeni- ja kehapuhastamisesmärkidel.
-  Kui külma ja kuuma vee ühenduste surve on väga erinev, tuleb need tasakaalustada.

## Paigaldamisjuhised

- Seadmestiku paigaldamine, läbipesu ja kontrollimine peab toimuma vastavalt kehtivatele normidele.
- Enne paigaldamist tuleb toodet kontrollida transpordikahjustuste osas  
Pärast paigaldamist ei tunnustata enam transpordi- või pinnakahjustuste kaebuseid.

## Tehnilised andmed

Töörõhk	maks. 1 MPa
Soovitatav töörõhk:	0,1 – 0,5 MPa
Kontrollsurve:	1,6 MPa
(1 MPa = 10 baari = 147 PSI)	
Kuuma vee temperatuur:	maks. 80 °C
Soovitatav kuuma vee temperatuur:	65 °C

Hansgrohe segisteid võib kasutada koos hüdrauliliselt ja termiliselt juhitavate boileritega, kui vee surve on vähemalt 0,15 MPa.

Toode on ette nähtud eranditult joogivee jaoks!

## Sümbolite kirjeldus



Ärge kasutage äädikhapet sisaldavat silikooni!



## Reguleerimine

Ühe juhtkangiga segisti kuuma vee piiraja reguleerimise kohta vt lk 36. Läbivoolu boilerite puhul pole reguleerimine vajalik.



## Mõõtude (vt lk 33)



## Läbivooludiagramm (vt lk 33)

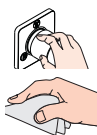

## Kasutamine (vt lk 37)

## Puhastamine

Puhastussoovitusi vt kaasasolevast brošüürist.



## Varuosad (vt lk 38)

XXX = Värvikood

000 = kroom

090 = kroom/kuld optik

800 = roostevaba optik



## Kontrollsertifikaat (vt lk 35)

Rike	Põhjus	Lahendus
Segisti käib raskelt	- Tööelement on katkine, lubjastunud	- Vahetage tööelement
Segisti tilgub	- Tööelement on katkine, sete	- Vahetage tööelement
Liiga madal sooja vee temperatuur, külma vett pole. Läbivoolu boiler hakkab tööle, kui on valitud külm vesi.	- Kuuma vee piirang valesi seatud - Ristvool	- Seadke kuuma vee piirang - Vahetage tööelement







## Drošības norādes

- ⚠ Montāžas laikā, lai izvairītos no spiedumiem un iegriezumiem, nepieciešams nēsāt cimdus.
- ⚠ Šo produktu drīkst izmantot tikai, lai mazgātos, higiēnai un ķermeņa tīrīšanai.
- ⚠ Jāzīdizina spiediena atšķirības starp aukstā un karstā ūdens pievadiem.

## Norādījumi montāžai

- Jaucējkrāns jāmontē, jāskalo un jāpārbauda atbilstoši spēkā esošajām normām.
- Pirms montāžas nepieciešams pārbaudīt, vai produktam transportēšanas laikā nav radušies bojājumi.  
Pēc iebūvēšanas bojājumi, kas radušies transportēšanas laikā, vai virsmas bojājumi netiek atzīti.

## Tehniskie dati

Darba spiediens: maks. 1 MPa  
 leteicamais darba spiediens: 0,1 – 0,5 MPa  
 Pārbaudes spiediens: 1,6 MPa  
 (1 MPa = 10 bar = 147 PSI)  
 Karstā ūdens temperatūra: maks. 80 °C  
 Ieteicamā karstā ūdens temperatūra: 65 °C

Hansgrohe jaucējkrānus var izmantot kombinācijā ar hidrauliski un termiski vadāmiem caurteces sildītājiem, ja plūsmas spiediens ir vismaz 0,15 MPa.

Izstrādājums ir paredzēts tikai dzeramajam ūdenim!

## Simbolu nozīme



Neizmantojiet silikonu, kas satur etiķskābi!



## Ieregulēšana

Viensviras jaucējkrāns ar siltā ūdens ierobežošanu, ieregulēšanu skat. 36. lpp. Kombinācijā ar caurteces sildītāju karstā ūdens ierobežošana nav nepieciešama.



## Izmērus (skat. 33. lpp.)



## Caurplūdes diagramma (skat. 33. lpp.)



## Lietošana (skat. 37. lpp.)



## Tīrīšana

Ieteikumus tīrīšanai skatiet pievienotajā brošūrā.



## Rezerves daļas (skat. 38. lpp.)

XXX = Krāsas

000 = hroma

090 = hroma/zelta

800 = tērauda



## Pārbaudes zīme (skat. 35. lpp.)

## Traucējums

## Iemesls



## Bojājumu novēršana

Jaucējkrāns smagi grozāms	- Bojāta kartuša, aizkaļķojusies	- Nomainīt kartušu
Jaucējkrāns pil	- Bojāta kartuša, nogulsns	- Nomainīt kartušu
Pārāk zema ūdens temperatūra, nav aukstā ūdens, izvēloties auksto ūdeni, sāk darboties caurteces sildītājs	- Nepareizi noregulāta karstā ūdens bloķēšana - Ūdens sajaukšanās	- Noregulēt karstā ūdens ierobežošanu - Nomainīt kartušu





## Sigurnosne napomene

-  Prilikom montaže se radi sprečavanja prignječenja i posekotina moraju nositi rukavice.
-  Proizvod sme da se koristi samo za kupanje, tuširanje i ličnu higijenu.
-  Velika razlika u pritisku između vruće i hladne vode mora biti izbalansirana.

## Instrukcije za montažu

- Armatura mora biti postavljena, isprana i testirana prema važećim normama.
- Pre montaže se mora proveriti da li je proizvod oštećen pri transportu. Nakon ugradnje se ne priznaju nikakve reklamacije koje se odnose na površinska i transportna oštećenja.

## Tehnički podaci

Radni pritisak:	maks. 1 MPa
Preporučeni radni pritisak:	0,1 – 0,5 MPa
Probni pritisak:	1,6 MPa
(1 MPa = 10 bar = 147 PSI)	
Temperatura vruće vode:	maks. 80 °C
Preporučena temperatura vruće vode:	65 °C

Hansgrohe armature se mogu koristiti u kombinaciji s hidraulički i termički kontrolisanim protočnim bojlerima ukoliko pritisak iznosi najmanje 0,15 MPa.

Proizvod je koncipiran isključivo za pijaću vodu!

## Opis simbola



Nemojte koristiti silikon koji sadrži sirćetnu kiselinu!



## Podešavanje

Da bi ste podesili ograničavač vruće vode na jednoručnim mešačima, molimo Vas da pogledate stranicu 36. Podešavanje nije potrebno ako koristite protočni bojler.



**Mere** (vidi stranu 33)



**Dijagram protoka** (vidi stranu 33)



**Rukovanje** (vidi stranu 37)



## Čišćenje

Preporuke za čišćenje možete naći u priloženoj brošuri.



**Rezervni delovi** (vidi stranu 38)

XXX = Oznake boja

000 = hrom

090 = dezen hrom/zlatna

800 = dezen plemeniti čelik



**Ispitni znak** (vidi stranu 35)

## Smetnja

## Uzrok



## Pomoć

Ručica se zaglavila	- Neispravna kartuša, nataloženi kamenac	- Zamenite kartušu
Slavina kaplje	- Neispravna kartuša, naslage kamenca	- Zamenite kartušu
Preniska temperatura tople vode, nema hladne vode. Protočni bojler se pali iako je puštena hladna voda.	- Ograničavač vruće vode nije dobro podešen - Ukršteni tok vode	- Podesite ograničavač vruće vode - Zamenite kartušu





## Sikkerhetshenvisninger

-  Bruk hansker under montasjen for å unngå klem- og kuttskader.
-  Dusjsystemet skal kun brukes for bade-, hygiene- og kroppshygiene.
-  Store trykkdifferanser mellom kaldt- og varmtvannstilkoblinger skal utlignes.

## Montagehenvisninger

- Armaturen skal monteres, spyles og sjekkes iht. gyldige standarder.
- Før montasjen skal produktet sjekkes for transportskader. Etter monteringen aksepteres ikke noen transport- eller overflateskader.

## Tekniske data

Driftstrykk	maks. 1 MPa
Anbefalt driftstrykk:	0,1 – 0,5 MPa
Prøvetrykk	1,6 MPa
(1 MPa = 10 bar = 147 PSI)	
Varmtvannstemperatur	maks. 80 °C
Anbefalt temperatur for varmt vann	65 °C

Armaturer fra Hansgrohe kan brukes sammen med hydraulisk og termisk strypte gjennomstrømningsovner når gjennomstrømningstrykket er på minst 0,15 MPa.

Produktet er utelukkende designet for drikkevann!

## Symbolbeskrivelse



Ikke bruk silikon som inneholder eddiksyre!



## Justering

Enhåndblandebatteri med varmtvannsbegrensning. For justering se side 36. I forbindelse med en gjennomstrømningsovn er det ikke nødvendig med varmtvannsbegrensning.



## Mål (se side 33)



## Gjennomstrømningsdiagram (se side 33)



## Betjening (se side 37)



## Rengjøring

Se vedlagt brosjyre for rengjøringsanbefalinger.



## Servicedeler (se side 38)

XXX = Oznake boja

000 = hrom

090 = dezen hrom/zlatna

800 = dezen plemeniti čelik



## Prøvemerket (se side 35)



Feil	Årsak	Feilrettelse
Armatur ikke lett bevegelig	- Kartusj defekt, forkalkning	- Kartusj byttes
Armatur drypper	- Kartusj defekt, avleiringer	- Kartusj byttes
For lav varmtvannstemperatur, ikke noe kaldtvann.	- Varmtvannsbegrensning er feil innstilt	- Varmtvannsbegrensning innstilles
Gjennomstrømningsovnen slår seg på når det velges kaldt vann.	- Krysstrømning	- Kartusj byttes



**Montasje se side 32**



## Указания за безопасност

-  При монтажа трябва да се носят ръкавици, за да се избегнат наранявания поради притискане или порязване.
-  Позволено е използването на продукта само за къпане, хигиена и цели на почистване на тялото.
-  Големите разлики в налягането между изводите за студената и топлата вода трябва да се изравняват.

## Указания за монтаж

- Арматурата трябва да се монтира, промие и провери в съответствие с валидните норми.
- Преди монтажа продуктът трябва да се провери за транспортни щети.
- След монтажа не се признават транспортни или повърхностни щети.

## Технически данни

Работно налягане:	макс. 1 МПа
Препоръчително работно налягане:	0,1 – 0,5 МПа
Контролно налягане:	1,6 МПа
(1 МПа = 10 bar = 147 PSI)	
Температура на горещата вода:	макс. 80 °C
Препоръчителна температура на горещата вода:	65 °C

Арматурите на Hansgrohe могат да се използват във връзка с хидравлично и термично управляеми проточни нагреватели, ако хидравличното налягане е минимум 0,15 МПа.

Продуктът е разработен само за питейна вода!

## Описание на символите



Не използвайте силикон, съдържащ оцетна киселина!



## Юстиране

Смесител с една ръкохватка с ограничител за топлата вода, юстирането вижте на стр. 36. Във връзка с проточни нагреватели не е необходима блокировка за топлата вода.



## Размери (вижте стр. 33)



## Диаграма на потока (вижте стр. 33)



## Обслужване (вижте стр. 37)



## Почистване

Вижте препоръките при почистване от приложената брошура.



## Сервизни части (вижте стр. 38)

XXX = Ozname boja

000 = hrom

090 = dezen hrom/zlatna

800 = dezen plemeniti čelik



## Контролен знак (вижте стр. 35)

## Неизправност

## Причина

## Помощ

Трудно подвижна арматура	- Дефектна гилза, покрита с варовик	- Сменете гилзата
Арматурата капе	- Дефектна гилза, отлагания	- Сменете гилзата
Твърде ниска температура на топлата вода, няма студена вода. Проточният нагревател се задейства, когато се избере студена вода	- Ограничението за топлата вода е грушно настроена	- Настройте ограничението за топлата вода
	- Кръстосване на потока	- Сменете гилзата



**Монтаж вижте стр. 32**



## Udhëzime sigurie

- ⚠ Për të evituar lëndimet e pickimeve ose të prerjeve gjatë procesit të montimit duhet që të vishni doreza.
- ⚠ Produkti duhet të përdoret vetëm qëllimet e banjave, të higjienës dhe të larjes së trupit.
- ⚠ Ndryshimet e mëdha të presionit mes lidhjeve të ujit të ftohtë dhe atij të ngrohtë duhen ekuilibruar.

## Udhëzime për montimin

- Armatura duhet montuar, shpërlarë dhe kontrolluar në bazë të normave të vlefshme.
- Përpara montimit duhet që produkti të kontrollohet për dëmtime nga transporti.  
Pas instalimit nuk do të njihet asnjë dëmtim nga transporti ose dëmtim i sipërfaqes.

## Të dhëna teknike

Presioni gjatë punës	maks. 1 MPa
Presioni i rekomanduar:	0,1 – 0,5 MPa
Presioni për provë:	1,6 MPa
(1 MPa = 10 bar = 147 PSI)	
Temperatura e ujit të ngrohtë	maks. 80 °C
Temperatura e rekomanduar e ujit të ngrohtë:	65 °C

Armaturat e Hansgrohe mund të përdoren në kombinim me ngrohës elektrikë të ujit të drejtuar në mënyrë hidraulike ose termike nëse presioni i rrjedhjes është minimumi 0,15 MPa.

Produkti është projektuar ekskluzivisht për ujë të pijshëm!

## Përshkrimi i simbolit



Mos përdorni silikon që në përbërje ka acid acetik.



### Justimi

Rubinet me ujë të përzier me kufizim të ujit të ngrohtë, justimi shih faqen 36. Në kombinim me ngrohësit elektrikë të ujit nuk ka nevojë për bllokadë të ujit të ngrohtë.



### Përmasat (shih faqen 33)



### Diagrami i qarkullimit (shih faqen 33)



### Përdorimi (shih faqen 37)



### Pastrimi

Për rekomandime mbi pastrimin shikoni broshurën bashkëngjitur.



### Pjesë ndërrimi (shih faqen 38)

XXX = Oznake boja

000 = hrom

090 = dezen hrom/zlatna

800 = dezen plemeniti çelik



### Shenja e kontrollit (shih faqen 35)

Dëmtim	Shkaku	Ndihme
Armatura punon rende	- Kartusha me defekt, me kalk	- Kembeni kartushen
Armatura pikon	- Kartusha me defekt, depozitime	- Kembeni kartushen
Temperaturë e ulët e ujit të ngrohtë, nuk ka ujë të ftohtë. Ngrohësi elektrik i ujit ndizet kur zgjidhet uji i ftohtë.	- Kufiri i ujit të ngrohtë është regjistruar gabim - Rrjedhje e kryqëzuar.	- Regjistroni kufirin e ujit të ngrohtë - Kembeni kartushen





## تنبيهات الأمان



يجب إرتداء قفازات لليد أثناء التركيب لتجنب حدوث أخطار الإنحشار أو الجروح.



لا يجب استخدام نظام الدش إلا في أغراض الاستحمام والأغراض الصحية وأغراض تنظيف الجسم.



يجب أن يكون تيار الماء الساخن والماء البارد متعادلين في الضغط.



## وصف الرمز

هام! لا تستخدم السليكون الذي يحتوي على أحماض!



### الضبط

لضبط محدد الماء الساخن في الخلاطات ذات المقبض الواحد، يرجى الرجوع إلى صفحة 34. ولا يلزم إجراء أي ضبط عند استخدام سخان مياه ذي تدفق مستمر.



## تعليمات التركيب

- يجب تركيب الوصلة واستخدامها واختبارها وفقاً للمعايير المعمول بها.
  - قبل القيام بعملية التركيب، يجب فحص المنتج للتأكد من خلوه من أية تلفيات ناتجة عن النقل.
- بعد القيام بعملية التركيب، لن يتم الاعتراف بوجود أية تلفيات سطحية أو تلفيات ناتجة عن عملية النقل.

أبعاد (راجع صفحة 31)

رسم للصراف

(راجع صفحة 31)

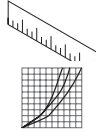

التشغيل (راجع صفحة 35)

التنظيف

للاطلاع على النصائح الخاصة بالتنظيف انظر الكتيب المرفق.



قطع الغيار (راجع صفحة 36)

الألوان = XXX

كروم = 000

كروم/لون ذهبي = 090

مظهر الإستنليس ستيل = 800



شهادة اختبار (راجع صفحة 35)



## المواصفات الفنية

- ضغط التشغيل: الحد الأقصى 1 ميجاباسكال
- ضغط التشغيل الموصى به: 0,5 – 0,1 ميجاباسكال
- ضغط الاختيار: 1,6 ميجاباسكال
- (1 ميجاباسكال = 10 بار = 147 PSI)
- درجة حرارة الماء الساخن: الحد الأقصى 80°C
- درجة الحرارة الموصى بها للماء الساخن: 65°C

يمكن استخدام خلاطات هانزجروهي مع سخانات تدفق الماء ذات التحكم الهيدروليكي و الحراري، مع ضغط تدفق لا يقل عن 0,15 ميجاباسكال.

المنتج مخصص فقط لماء الشرب!

العطل	السبب	العلاج والإصلاح
الخلاط ثقيل الحركة	- الخرطوشة تالفة، تراكم عليها الجير	- قم بتغيير الخرطوشة
تساقط قطرات مياه من الخلاط	- الخرطوشة تالفة، متراكم عليها الترسبات	- قم بتغيير الخرطوشة
المحول لا يعمل	- الرواسب	- تنظيف الخلاط وتشحيم الحلقة الدائرية.
	- ضغط الماء منخفض للغاية	- ارفع ضغط الماء
	- المحول تالف	- قم بتغيير المحول





**Starck**  
10615000  
10615003

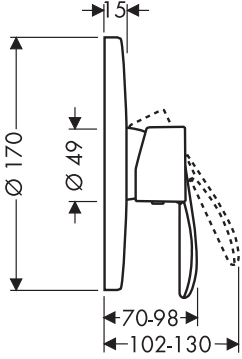

**Carlton**  
17615XXX

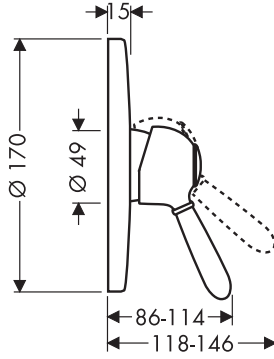

**Steel**  
35625800

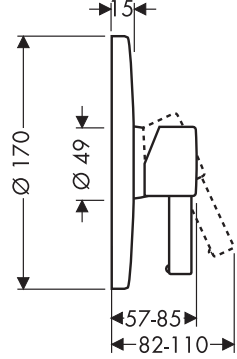

**Starck** 10615000 / 10615003  
**Carlton** 17615XXX / **Steel** 35625800

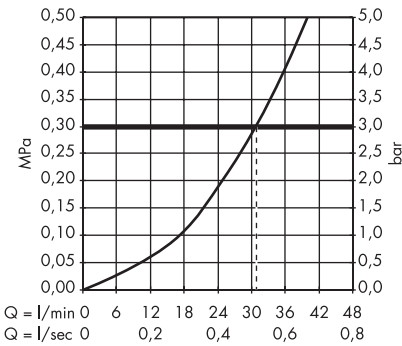

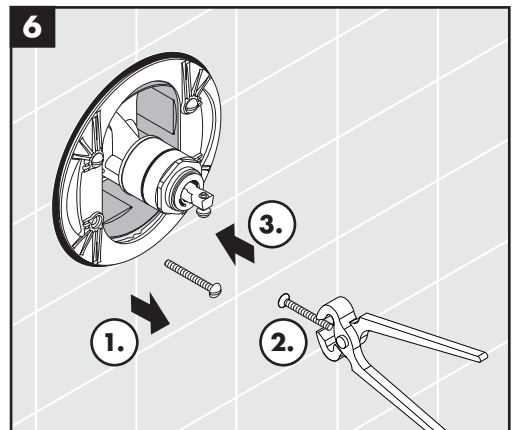
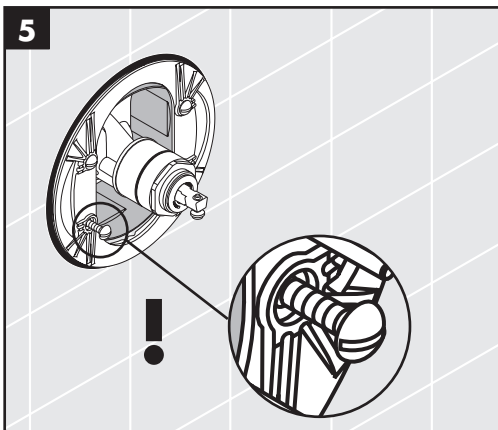
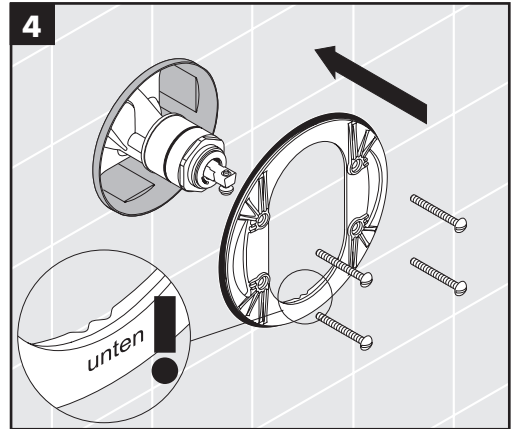
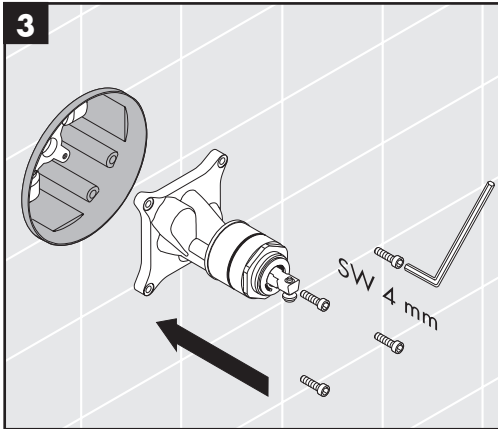
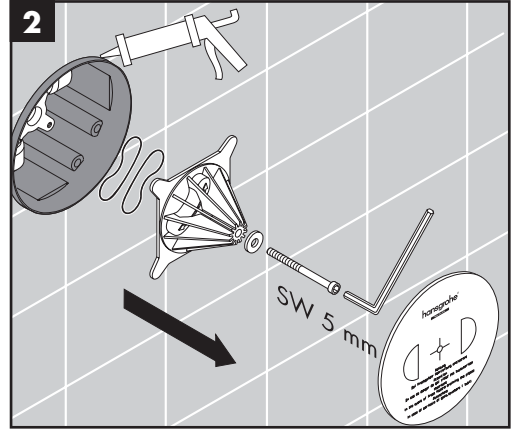
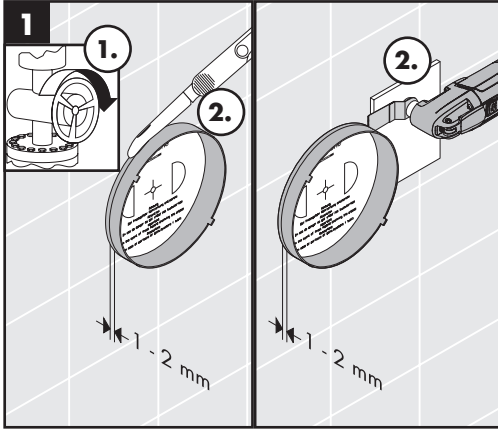



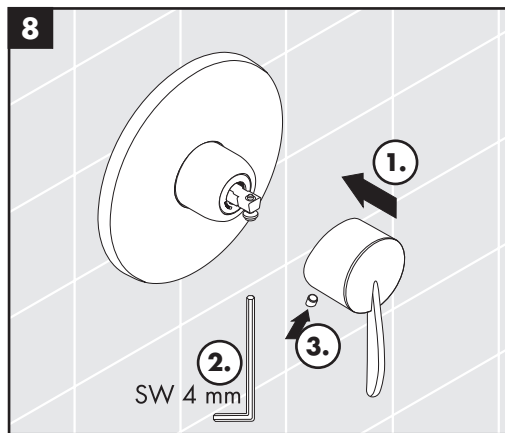
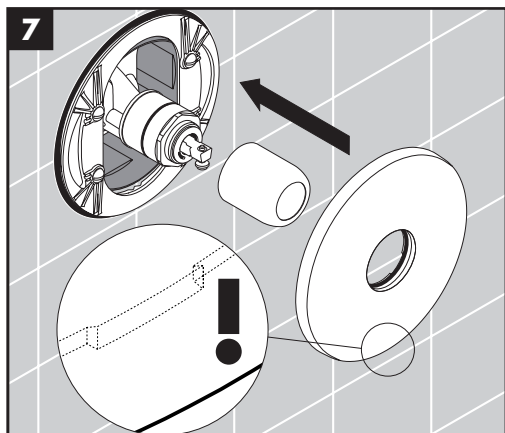



60 °C



10 °C



0,3 MPa  
0,3 МПа  
0,3 میجاباسکال

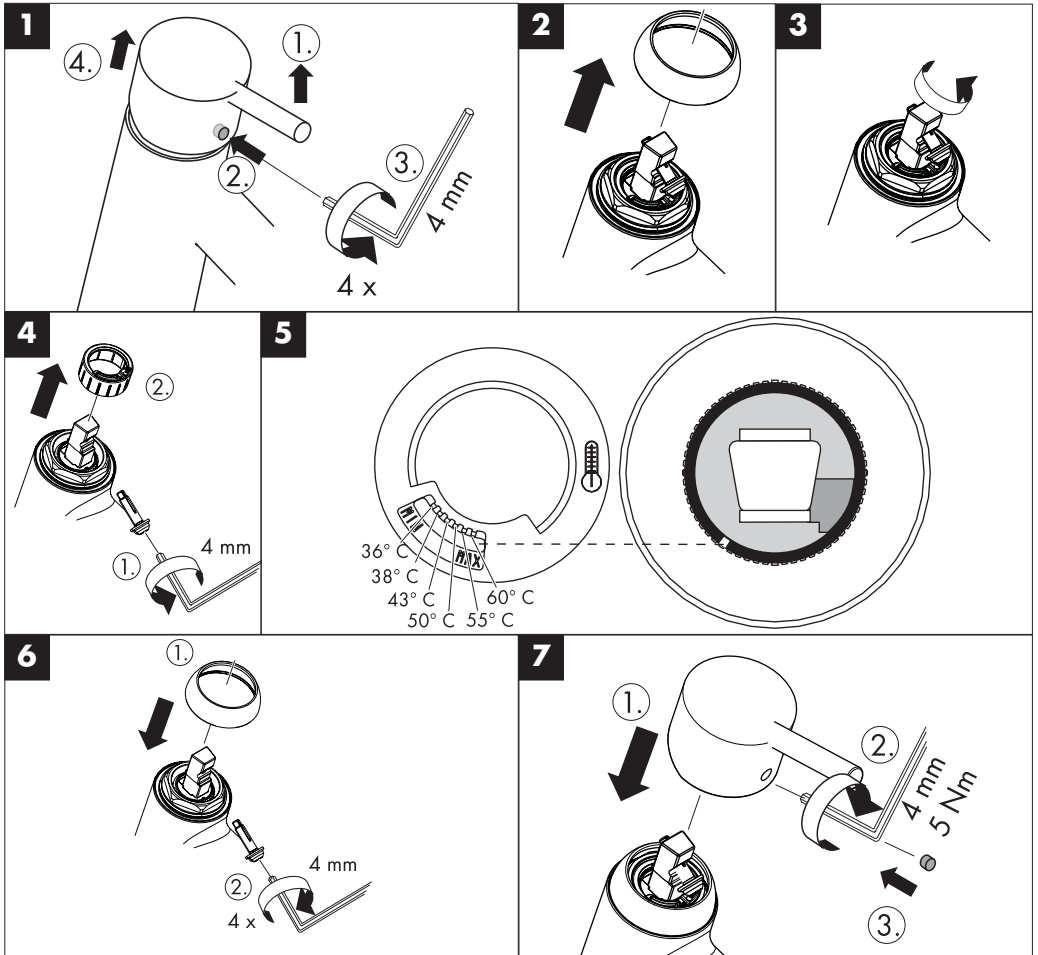

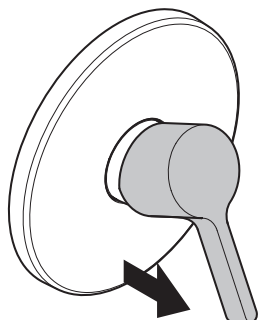

öffnen / ouvert / open / aperto / abierto / open / åbne /  
 abrir / otworzyć / otevřít / otvorit / 开 / открыть /  
 nyitás / avaaminen / öppna / atidaryti / Отваранje /  
 açmak / deschide / ανοικτό / odpreti / avage / atvērt /  
 otvoriti / åpne / отваряне / hare / فتح

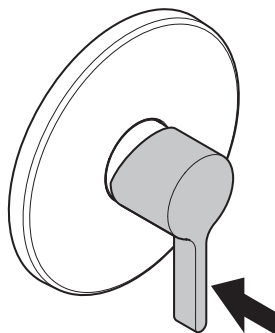

schließen / fermé / close / chiudere / cerrar / sluiten /  
 lukke / fechar / zamknąć / zavřít / uzavriť / 关 /  
 закрыть / bezárás / sulkeminen / stänga / uždaryti /  
 Zatvaranje / kapatmak / închide / κλειστό / zapreti /  
 sulgege / aizvērt / zatvori / lukke / затваряне / mbylle /  
 إغلاق

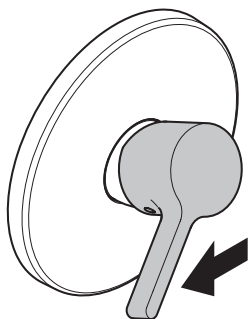

warm / chaud / hot / caldo / caliente / warm / varmt /  
 quente / ciepła / teplá / teplá / 热 / горячая / meleg /  
 lämmin / varmt / karštas / Vruća voda / sıcak / cald /  
 ζεστό / toplo / kuum / karsts / topla / varm / тепло /  
 i ngrohtë / ساخن

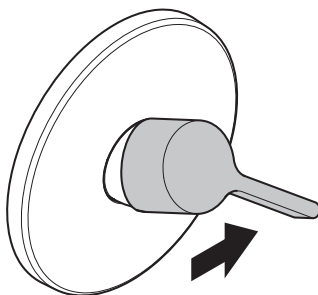

kalt / froid / cold / freddo / frío / koud / koldt / fria /  
 zimna / studená / studená / 冷 / холодная / hideg /  
 kylmä / kallt / šaltas / Hladno / soğuk / rece / крло /  
 mrzlo / külm / auksts / hladno / kaldt / студено / i fhohtë /  
 بارد



	P-IX	DVGW	SVGW	ACS	WRAS	MCA	KIWA
<b>10615000</b>	PA-IX 9710/IB		X	X	X		X
<b>17615XXX</b>	PA-IX 9710/IB		X	X	X		X
<b>35625800</b>	PA-IX 9710/IB		X	X	X		X



