

VitrA

: 3/6

:711-5800

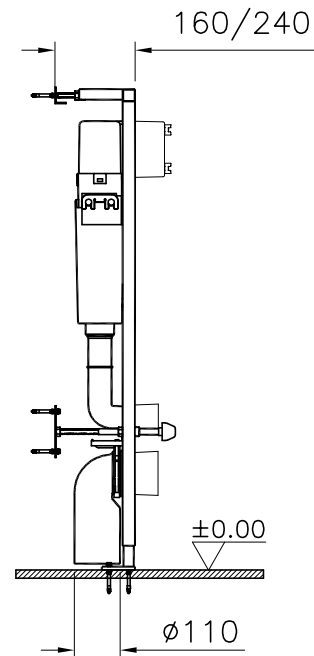
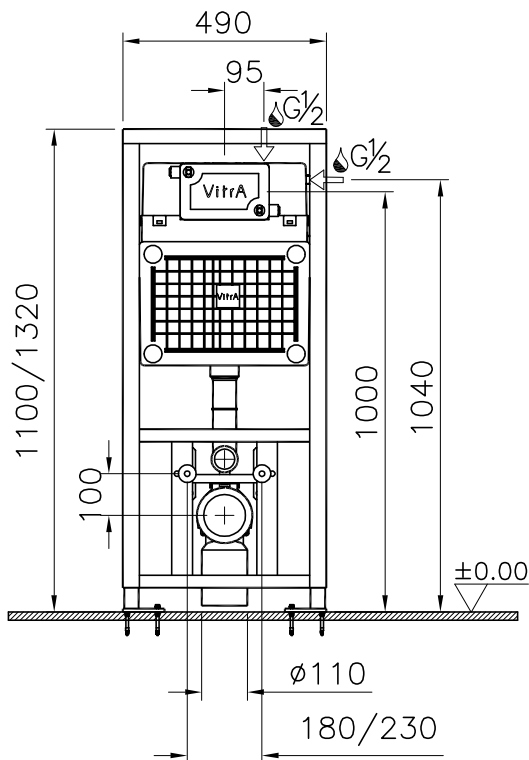

*We reserve the right to make technical modifications and alter colours without prior notice.

*VitrA önceden haber vermeksizin, ürünler ve teknik detaylarında değişiklik yapma hakkını saklı tutar.

*Wir behalten uns das Recht auf technische Änderungen und Anpassungen der Farben ohne vorherige Ankündigung vor.